

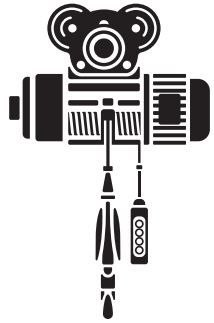

Indice Index

L'AZIENDA	THE COMPANY	5
QUALITÀ, CERTIFICAZIONE E MARCATURA CE	QUALITY, CERTIFICATIONS AND CE MARK	6
GAMMA DEI PARANCHI ELETTRICI A FUNE SERIE XM	RANGE OF WIRE ROPE HOISTS XM SERIES	9
Configurazioni standard	Standard configurations	10
Componenti	Components	12
Prestazioni	Performance	14
Caratteristiche	Characteristics	15
Esempio di composizione del codice del paranco	Abbreviation of the xm range of misia wire rope hoist	15
PARANCHI A FUNE SERIE XM STANDARD	STANDARD XM SERIES ROPE HOISTS	17
Caratteristiche tecniche	Technical data	18
S2 - 2 TIRI DI FUNE (2/1) - Fig. 5 Appoggiato - Fig. 5C1 Sospeso	S2 - 2 ROPE FALLS (2/1) - Fig. 5 Supported - Fig. 5C1 Suspended	22
S4 - 4 TIRI DI FUNE (4/1) - Fig. 5 Appoggiato - Fig. 5C1 Sospeso	S4 - 4 ROPE FALLS (4/1) - Fig. 5 Supported - Fig. 5C1 Suspended	24
S2 - 2 TIRI DI FUNE (2/1) - Fig. 3 a ingombro normale	S2 - 2 ROPE FALLS (2/1) - Fig. 3 normal headroom	26
S4 - 4 TIRI DI FUNE (4/1) - Fig. 3 a ingombro normale	S4 - 4 ROPE FALLS (4/1) - Fig. 3 normal headroom	28
S2 - 2 TIRI DI FUNE (2/1) - Fig. 83 monotrave a ingombro ridotto	S2 - 2 ROPE FALLS (2/1) - Fig. 83 monorail low headroom	30
S4 - 4 TIRI DI FUNE (4/1) - Fig. 83 monotrave a ingombro ridotto	S4 - 4 ROPE FALLS (4/1) - Fig. 83 monorail low headroom	31
S2 - 2 TIRI DI FUNE (2/1) - Fig. 53/Fig. 53C1 birotaia con paranco sospeso o appoggiato	S2 - 2 ROPE FALLS (2/1) - Fig. 53/Fig. 53C1 double beam trolley crab with hoist supported or suspended	32
S4 - 4 TIRI DI FUNE (4/1) - Fig. 53/Fig. 53C1 birotaia con paranco sospeso o appoggiato	S4 - 4 ROPE FALLS (4/1) - Fig. 53/Fig. 53C1 double beam trolley crab with hoist supported or suspended	34
PARANCHI A DOPPIA USCITA DAL TAMBURO D2 (4/2) TIRO CENTRALE	HOISTS WITH DOUBLE OUTLET FROM THE DRUM D2 (4/2) TRUE VERTICAL LIFT	38
Fig. 5 Appoggiato - Fig. 5C1 Sospeso	Fig. 5 Supported - Fig. 5C1 Suspended	39
Fig. 3 a ingombro normale	Fig. 3 normal headroom	40
Fig. 83 monotrave a ingombro ridotto	Fig. 83 monorail low headroom	41
Fig. 53/Fig. 53C1 birotaia con paranco sospeso o appoggiato	Fig. 53/Fig. 53C1 double beam trolley crab with hoist supported or suspended	42
PARANCHI SPECIALI	SPECIAL HOIST	44
Tipo DC2 a doppia uscita di fune e singolo tiro contrapposto rinviato	Type DC2 opposite double rope output with 2/2+2 rope falls	45
Tipo DC1 a doppia uscita e singolo tiro contrapposto	Type DC1 opposite double rope output with 2/1+1 rope falls	46
PARANCHI SPECIALI S2 - A 2 TIRI DI FUNE (2/1) CORSE GANCIO LUNGHE	SPECIAL HOIST S2 - 2 ROPE FALLS (2/1) HIGH LIFTING HEIGHT	47
Fig. 5 Appoggiato - Fig. 5C1 Sospeso	Fig. 5 Supported - Fig. 5C1 Suspended	47
Fig. 3 a ingombro normale	Fig. 3 normal headroom	48
Fig. 53/Fig. 53C1 birotaia con paranco sospeso o appoggiato	Fig. 53/Fig. 53C1 double beam trolley crab with hoist supported or suspended	49
PARANCHI SPECIALI A SINGOLA USCITA FUNE DAL TAMBURO 6/1	SPECIAL HOIST WITH SINGLE OUTLET FROM THE DRUM 6/1	50
SR6 a 6 tiri di fune (6/1) - Fig. 5 Appoggiato - Fig. 53 Carrello paranco monorotaia	SR6 - 6 rope falls (6/1) - Fig. 5 Supported - Fig. 53 Hoist trolley birail	50
PARANCHI SPECIALI A SINGOLA USCITA FUNE DAL TAMBURO 8/1	SPECIAL HOIST WITH SINGLE OUTLET FROM THE DRUM 8/1	51
SR8 a 8 tiri di fune (8/1) - Fig. 5 Appoggiato - Fig. 53 Carrello paranco monorotaia	SR8 - 8 rope falls (8/1) - Fig. 5 Supported - Fig. 53 Hoist trolley birail	51
CARRELLI	TROLLEYS	52
Carrelli per monorotaie rettilinee	Trolleys for straight monorail	53
Carrelli per monorotaie curve	Trolleys for curved monorail	53
Carrelli birotaia per gru a ponte	Birail trolleys for bridge crane	54
ACCESSORI	ACCESSORIES	55
Bozzelli	Hook blocks	56
Limitatori di carico Serie OL	Overload limiter OL Series	57
Riduttori a albero cavo	Hollow shaft gear unit	58
Testate per gru a ponte	Girders end-carriages	59
Componenti elettrici	Electrical components	60
Sistemi di alimentazione	Energy supply systems	60





MISIA



L'azienda

The company

MISIA produce paranchi a fune in grande serie da più di 30 anni.

Oltre 70.000 paranchi a fune venduti in Italia e all'estero sono attualmente operanti in ogni settore industriale. La gamma serie XM si compone di 11 grandezze con portate da 1.000 a 50.000 kg disponibili in differenti versioni: fisso appoggiato, fisso sospeso, con carrello monotrave normale, con carrello monotrave ad altezza ridotta, con carrello bitrave appoggiato, con carrello bitrave sospeso.

Con le serie standard è possibile la realizzazione di combinazioni adatte a soddisfare qualsiasi esigenza specifica del cliente: portata, corsa gancio, velocità di sollevamento, velocità di traslazione, tipo di servizio determinato dalle classi di utilizzo secondo la classificazione della Federation Europeenne de la Manutention (FEM sez. IX). I paranchi MISIA sono tutti conformi alla Direttiva Macchine 2006/42/CE.

MISIA has manufactured an extensive range of hoists for more than 30 years.

Over 70.000 wire rope units have been sold worldwide and are operational in every sector of industry.

The XM series range consists of 11 sizes with capacities between 1.000 Kg and 50.000 Kg.

The hoist units are available in different configurations: low headroom monorail, standard headroom monorail, foot mounted (fixed or suspended), double rail "crab" units (supported or inverted).

With these configurations, this standard range allows the XM series to meet any requirements or application: capacity, hook travel, travel and hoisting speed, load spectrum based on the FEM classification (FEM section IX). All MISIA hoists comply with the Machine Directive 2006/42/CE.



 MISIA PARANCHI S.r.l. VIA DEI LAVORATORI, 9/11 20092 CINISELLO B.MO MILANO ITALY		
PARANCO ELETTRICO A FUNE ELECTRIC ROPE HOIST		TIPO TYPE
PORTATA CAPACITY	kg.	GRUPPO GROUP FEM
CORSA GANCIO HEIGHT OF LIFT	m.	
VELOCITA' SOLLEV. HOISTING SPEED	m/min.	ANNO DI FABBRICAZIONE MANUFACTURING YEAR
		POTENZA POWER
		ALIMENTAZIONE SUPPLY
		V- Hz

Qualità e certificazione

Quality and certifications

La documentazione commerciale, così come i manuali tecnici di istruzione per il montaggio, l'uso e la manutenzione del paranco elettrico a fune che sempre accompagnano la vendita di ogni paranco, è redatta in considerazione delle norme armonizzate UNI-EN 292 - 1a e 2a parte.

I paranchi elettrici a fune della serie XM sono prodotti in conformità alla Direttiva Comunitaria 89/392CE denominata Direttiva Macchine, con legge di recepimento della legislazione ITALIANA DPR 459 del 24 luglio 1996 e direttiva 98/37/CE e 2006/42/CE.

I componenti che fanno parte del paranco rispondono ai requisiti richiesti dalla Direttiva Macchine e la marcatura CE testimonia la conformità dell'intera macchina.

MISIA ha conseguito per la produzione e la distribuzione dei paranchi elettrici a fune la certificazione del sistema di qualità aziendale conformemente alle norme ISO 9001:2008, con rilascio da parte della società di verifica BV Italia certificata ACCREDIA.

The commercial documentation, together with the technical instruction manuals for the installation, use and maintenance of electric rope hoists, which accompany the sale of every machine, have been drawn up in accordance with unified standards UNI EN 292 – parts 1 and 2.

The XM series electric rope hoists are produced in accordance with the Machine Directive 89/392/EEC, with the Italian law DPR 459 dated July 24th, 1996 and the Directive 98/37/EEC and 2006/45/EEC.

The components of the hoist comply with the requirements of the Directive and CE Mark confirms the conformity of the whole equipment.

MISIA produces and sells the electric rope hoists under a registered quality control system approved to ISO 9001:2008, with issue from the Certification Company BV Italia certificates: ACCREDIA.



Marcatura CE

CE mark

La leadership e l'affidabilità di MISIA quale costruttore di paranchi elettrici a fune sono confermate e garantite dalla assunzione delle responsabilità derivanti dalla marcatura CE.

Ogni macchina, infatti, prima di essere immessa sul mercato e quindi prima di essere marcata CE, è scrupolosamente controllata e collaudata in tutte le sue parti e componenti.

Tutte le macchine sono dotate, oltre alla dichiarazione di conformità CE, di garanzia la cui validità è di 2 ANNI DALLA CONSEGNA.

The leadership and reliability of MISIA as an electric rope hoist manufacturer are confirmed and guaranteed by our taking on the responsibilities resulting from the CE mark.

Before being made available for sale and CE marked, each hoist has all its parts and/or components thoroughly inspected and tested.

In addition to the CE declaration of conformity, all the machines are guaranteed for 2 YEARS FROM DELIVERY.

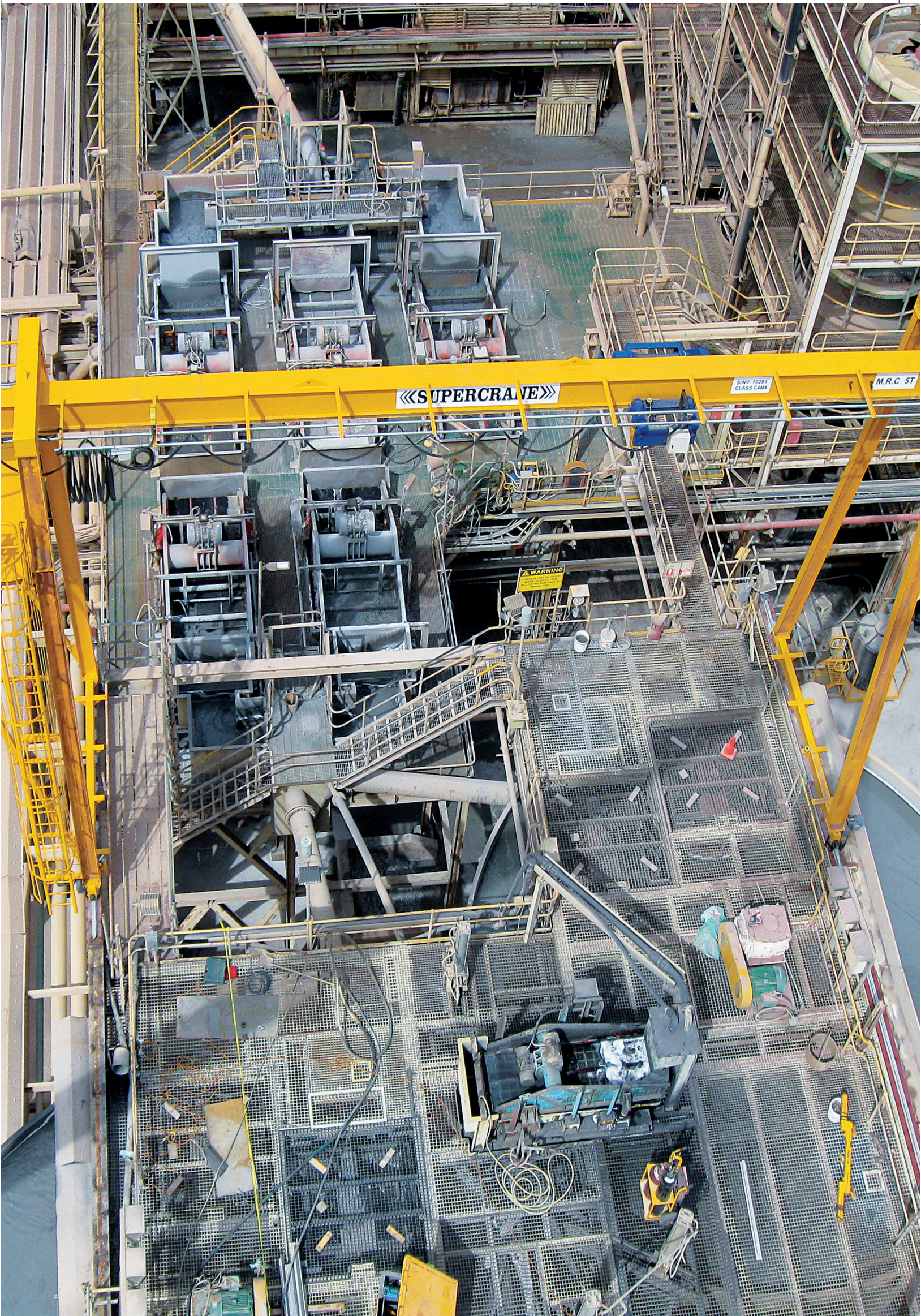

«SUPERCRANE»

S/N: 10291
CLASS C484

M.R.C 5T

WARNING



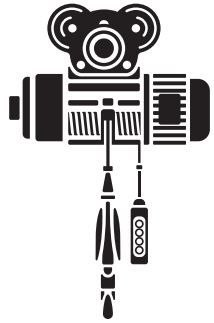

MISIA

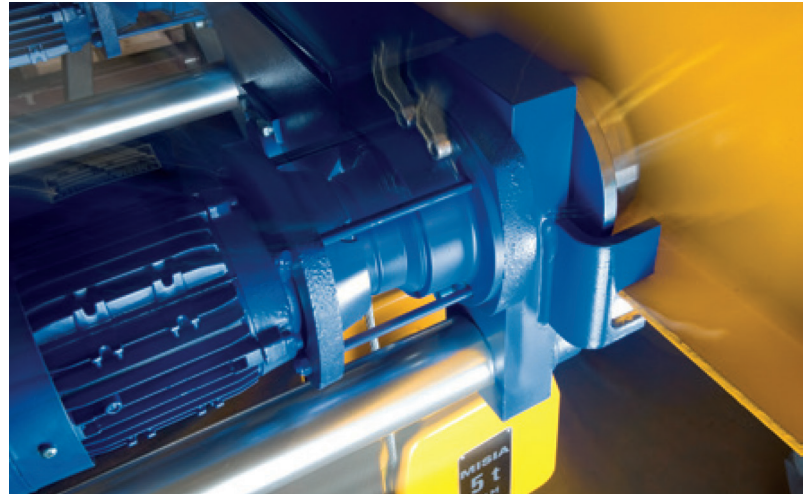

Gamma dei paranchi elettrici a fune serie XM

Range of wire rope hoists XM series

La costruzione di paranchi elettrici a fune in versione standard costituisce oltre il 90% dell'intera produzione. Questo dato conferma la validità e la flessibilità del prodotto MISIA, in grado di adattarsi a moltissimi impieghi tipici nelle operazioni di sollevamento industriale senza costringere l'utente a richieste particolari. La nuova produzione standard XM comprende 11 grandezze costruttive per portate da 1.000 kg a 50.000 kg a 2 o 4 tiri di fune, con varie velocità di sollevamento da 1,5 m/min. a 12 m/min. e predisposti per esecuzione "appoggiata" o "sospesa" (per posizionamento fisso o su carrello).

È inoltre disponibile un'ampia gamma di carrelli di traslazione in versione bitrave e monotrave a ingombro normale e ingombro ridotto, e una gamma di paranchi speciali con corse gancio da 32 a 56 m con portate da 1.600 a 5.000 kg a due tiri di fune "S2", da 1.600 a 16.000 kg con doppia uscita dal tamburo "D2", e altre esecuzioni speciali su richiesta della clientela.

Manufacture of the standard version of XM series wire rope hoists accounts for over 90% of the company's production.

This confirms the flexibility of the MISIA product in adapting to many industrial lifting applications without subjecting the user to a bespoke product.

The production of the new XM series includes 11 construction sizes for capacities between 1.000 Kg and 50.000 Kg, 2 or 4 rope falls, lifting speeds ranging from 1,5 m/min to 12 m/min, feet mountings allowing "supported" or "suspended" fixing (for foot mounted or double rail "crab" units).

A wide range of travelling trolleys are also available in either double or monorail version, with the option of low or standard headroom, and a range of hoists with hook travel from 32 to 56 m, capacity from 1600 to 5000 Kg, 2 rope falls, and hoists with double outlet rope from the drum (4/2 reeving), capacity from 1600 to 25000 Kg. Special features are available upon request.

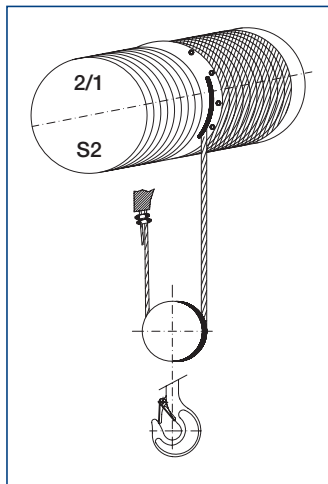
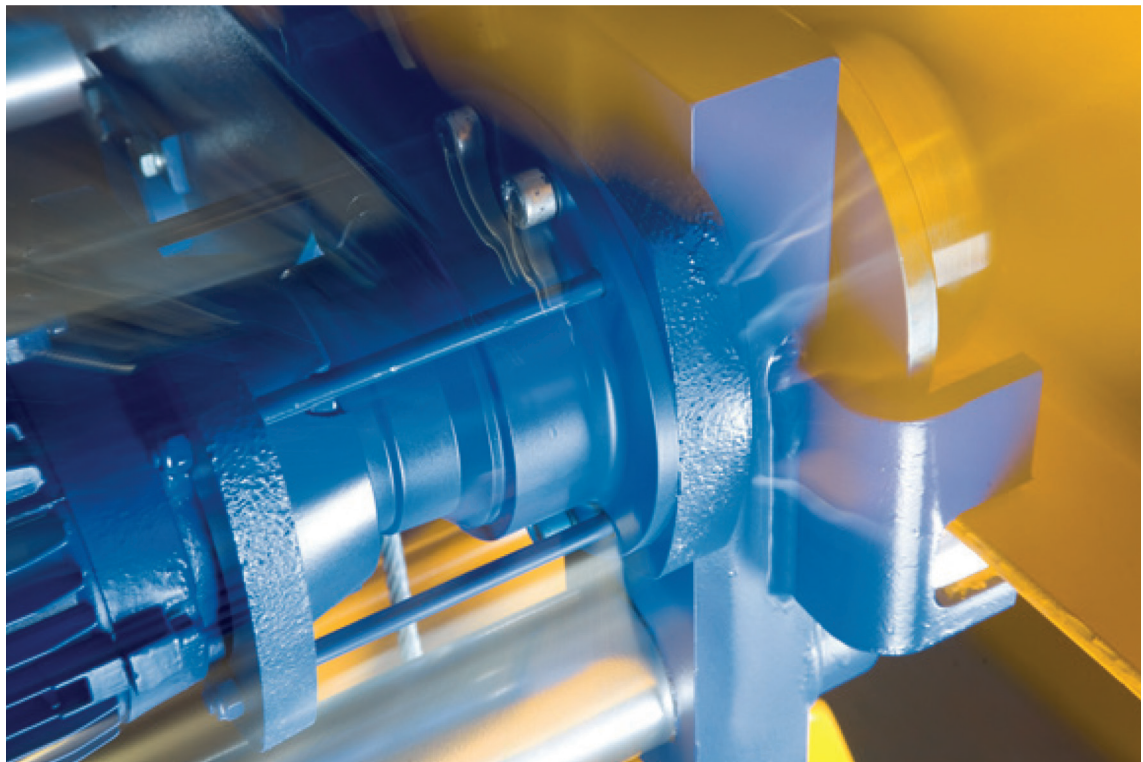

S2 - 2 TIRI DI FUNE (2/1)
S2 - 2 ROPE FALLS (2/1)

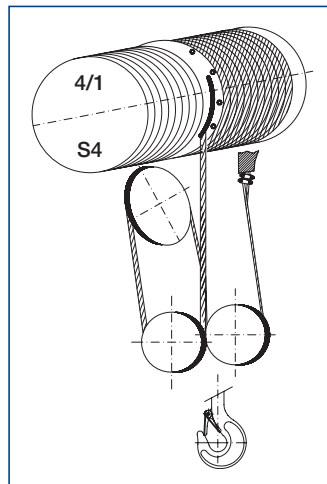

S4 - 4 TIRI DI FUNE (4/1)
S4 - 4 ROPE FALLS (4/1)

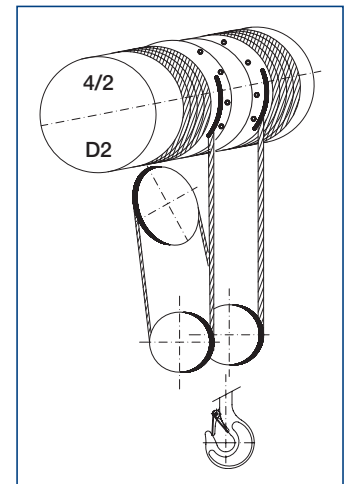

D2 - 4 TIRI DI FUNE (4/2)
TIRO CENTRALE
D2 - 4 ROPE FALLS (4/2)
TRUE VERTICAL LIFT

Configurazioni standard

Standard configurations

I paranchi elettrici a fune MISIA della serie XM sono disponibili nelle seguenti quattro configurazioni standard:

Versione S2 a due tiri di fune

Per portate da 1000 kg a 16000 kg in esecuzione “appoggiata” o “sospesa”.

Versione S4 a quattro tiri di fune

Per portate da 2000 kg a 32000 kg in esecuzione “appoggiata” o “sospesa”.

Versione D2 con tiro centrale

Per portate da 1600 kg a 25000 kg.

Solo in esecuzione “appoggiata”

Per portate da 20000 kg a 25000 kg a 2 tiri di fune.
Per portate da 40000 kg a 50000 kg a 4 tiri di fune.

The XM series of Misia wire rope hoist are available in the followings configurations:

S2 version (2 rope falls)

Lifting capacity from 1000 kg to 16000 kg either supported or suspended.

S4 version (4 rope falls)

Lifting capacity from 2000 kg to 32000 kg either supported or suspended.

D2 version (true vertical lift)

Lifting capacity from 1600 kg to 25000 kg.

Only in “supported” execution

For capacities from 20000 kg up to 25000 kg 2 rope falls.
For capacities from 40000 kg up to 50000 kg 4 rope falls.

TIPO 5



Paranco standard senza carrello.
Foot mounted hoist without trolley.

TIPO 3



Paranco con carrello monotrave a ingombro normale.
Per portate da 1000 kg a 32000 kg. Versione S2-S4.

Monorail hoist fitted with standard headroom trolley.
For capacities from 1000 kg up to 32000 kg. Version S2-S4.

TIPO 53

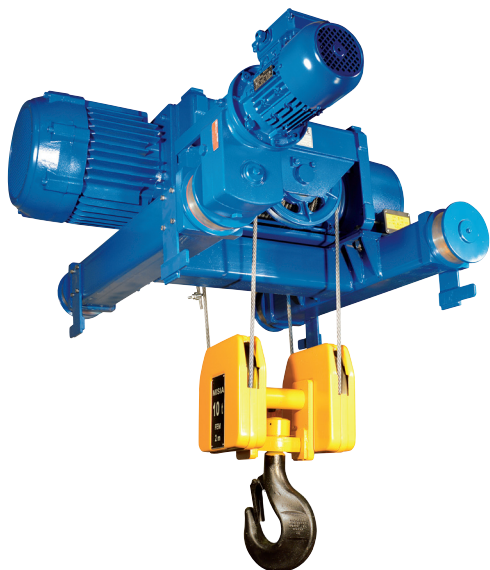

Paranco con carrello bitrave.
Per portate da 1000 kg a 32000 kg in esecuzione paranco
“appoggiato” o “sospeso” versione S2-S4.

Solo in esecuzione “appoggiata”

Per paranco in versione S2 per portate da 20000 kg a 25000
kg, versione S2 da 40000 kg a 50000 kg in versione S4.

Double rail “crab” unit.

For capacities from 1000 kg up to 32000 kg either supported
or suspended, version S2-S4.

Only in supported execution

For capacities from 20000 kg up to 25000 kg 2 rope falls, for
capacities from 40000 kg up to 50000 kg 4 rope falls.

TIPO 83



Paranco con carrello monotrave a ingombro ridotto.
Per portate da 1000 kg a 10000 kg. Versione S2-S4.

Low headroom monorail hoist trolley.

For capacities from 1000 kg up to 10000 kg. Version S2-S4.

Componenti

Components

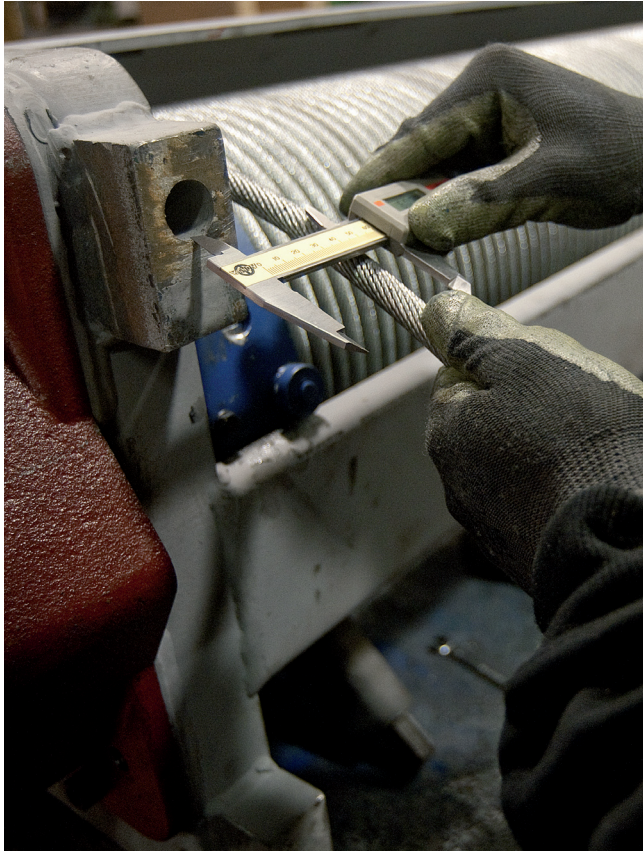

Limitatore di carico

Load limiter

Tutti i paranchi della Serie "XM" a 2 e 4 tiri di fune hanno un dispositivo di limitazione del carico.

I limitatori di carico intervengono sul circuito ausiliario segnalando il massimo carico nominale e, in caso di sovraccarico, interrompono l'operazione di salita e i movimenti di traslazione.

All "XM" series hoists with 2 and 4 rope falls are endowed with overload limiters (OLL) with two reaction thresholds.

The OLL acts on the auxiliary circuit by:

- activating a WARNING (1st stop);
- stopping both lifting and travel actions (2nd stop).

When the OLL reaches the 2nd stop the only possible action is load lowering.

Guidastringifune

Rope guide

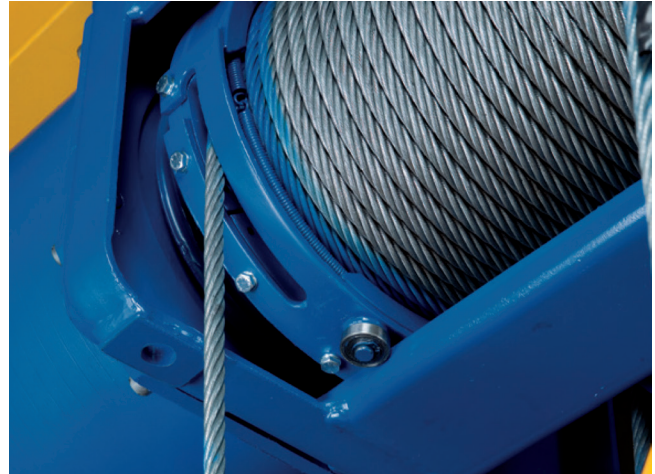

Il dispositivo guidafune è costituito essenzialmente da due elementi: un anello di guida ed una molla di compressione, che permettono di guidare correttamente la fune sulle gole del tamburo.

L'anello di guida mantiene in posizione la fune durante lo svolgimento, impedendole di deviare al pendolamento del carico, è guidato sulla traversa inferiore e scorre con cuscinetti a sfere di tipo schermato e autolubrificanti.

The rope guide consists of two parts: the guide ring and pressure spring. The pressure spring ensures that the rope sits correctly into the drum groove whilst the guide ring always maintains the rope in the correct position preventing the rope from coming off the drum groove. The guide is a robust design fitted with high quality bearings. Movement of the guide across the drum activates the up/down limit switch.

Riduttore

Hoist gearbox

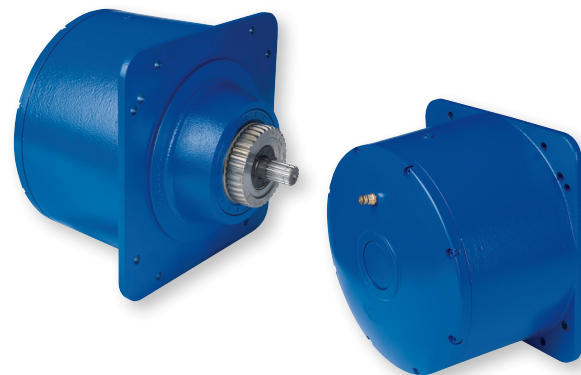

Il riduttore planetario a due o tre stadi provvede a ridurre la velocità di rotazione del motore elettrico al numero di giri necessario per il tamburo. Tutti gli ingranaggi del riduttore sono di acciaio di alta qualità trattati termicamente.

The 2 or 3 stage planetary gearbox reduces the speed of the electric motor to the required rpm of the drum. Each individual planetary gear is manufactured using heat-treated high quality steel.

Carrelli ad ingombro ridotto

Low headroom trolleys

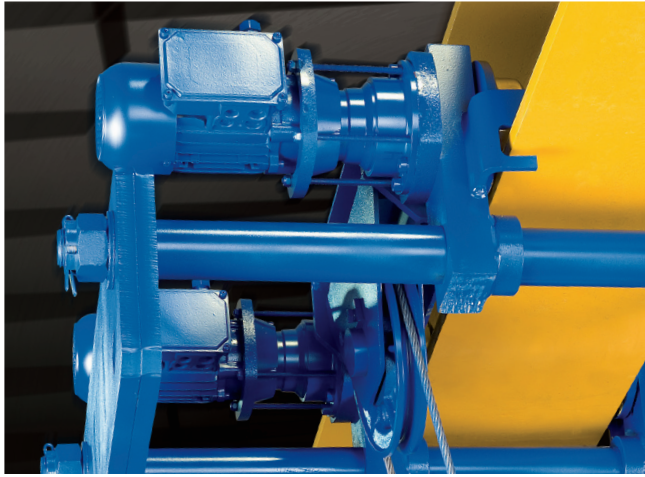

I carrelli ad ingombro ridotto sono dotati di 2 gruppi di traslazione costituiti da motoriduttori di tipo planetario con motori a doppia velocità autofrenanti e collegamento diretto alle ruote e quindi senza dentature esterne.

The low headroom trolley consists of two electric trolley motors fitted onto planetary gearboxes.

The trolley is of a live axle design with the gearboxes fitting directly onto the drive shaft of the wheels removing the need of external gears.

Carrelli monotrave ad ingombro normale

Standard headroom trolleys

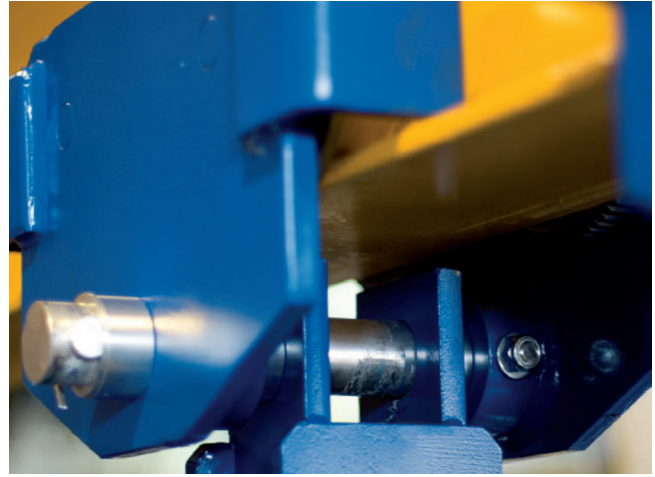

Sono realizzati con un perno di sospensione centrale che consente l'appoggio continuo di tutte le ruote indipendentemente dalla planarità della trave di scorrimento.

The standard headroom monorail design enables the hoist to operate directly under and parallel with the crane or runway beam. The hoist is suspended via drive trolley.

Motore cilindrico autofrenante

Self braking cylindrical motor

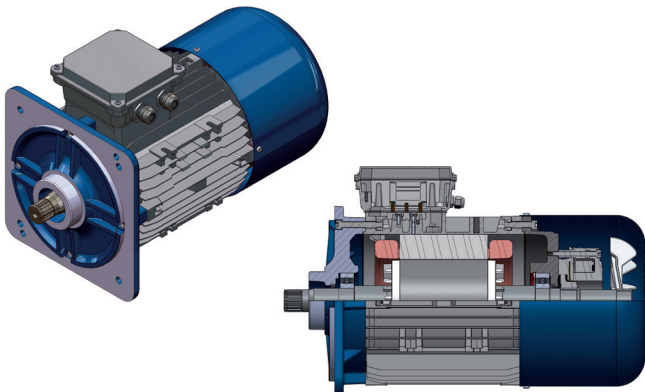

Motore elettrico asincrono trifase a 1 o 2 velocità a rotore cilindrico, con freno a dischi in C.C. Il motore a singola polarità, può essere azionato con inverter, per ottenere la velocità lenta richiesta oltre alle rampe di accelerazione e decelerazione.

The three-phase asynchronous electric motor with cylindrical rotor and disc brake is available in both single or dual speed option. The single polarity motor allows inverter control to be fitted offering further speed control to suit the application requirements.

Motore conico autofrenante

Self braking conical motor



Motore elettrico asincrono trifase a 1 o 2 velocità a rotore conico e freno conico incorporato azionato da una molla elicoidale. Lo sblocco del freno viene provocato dallo spostamento assiale del rotore all'inserimento della tensione.

Asynchronous electric motor 1 o 2 speeds conical rotor and conical brake included actuated by a helical spring. Brake release is caused by the axial displacement of the rotor by turning on the power.

Prestazioni Performance

Scelta del gruppo FEM in funzione del servizio e tempo totale di utilizzo. L'intensità di servizio del paranco viene determinata in base a due parametri:

- a) classe di funzionamento;
- b) tipo di servizio.

Selection of the FEM group is determined by two parameters:

- a) running time;
- b) duty.



L1 LEGGERO L1 LIGHT DUTY

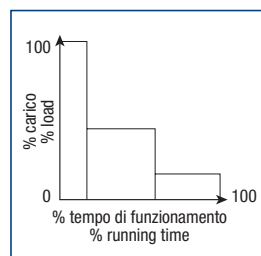

Per paranchi che sollevano raramente il carico massimo e prevalentemente carichi ridotti.

Hoist seldom lifting the maximum load and mostly light loads.

L2 MEDIO L2 MEDIUM DUTY

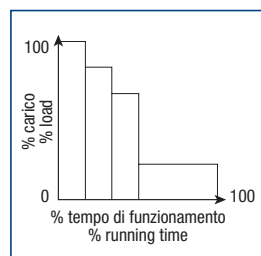

Per paranchi che sollevano all'incirca nello stesso rapporto carico massimo, carichi medi e ridotti.

Hoist lifting maximum medium and light loads at an even ratio.

L3 PESANTE L3 HEAVY DUTY

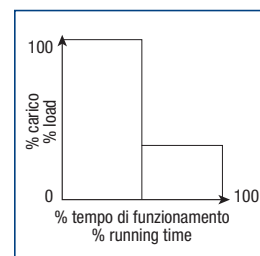

Per paranchi che frequentemente sollevano il carico massimo e normalmente carichi medi.

Hoists frequently lifting the maximum load and normally medium loads.

L4 MOLTO PESANTE L4 VERY HEAVY DUTY

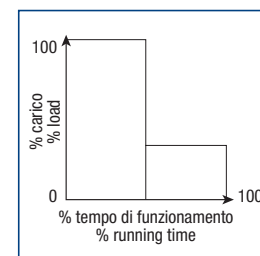

Per paranchi che sollevano regolarmente carichi prossimi al valore massimo.

Hoists regularly lifting loads near the maximum capacity.

Tipo di servizio Duty class	Tempo di utilizzo "T" Running time "T"	
L1 - Leggero L1 - Light duty	6300	12500
L2 - Medio L2 - Medium duty	3200	6300
L3 - Pesante L3 - Heavy duty	1600	3200
L4 - Molto pesante L4 - Very heavy duty	800	1600
FEM	1A m	2 m

COMPARAZIONE GRUPPI FEM-ISO COMPARISON FEM-ISO GROUPS

FEM sez. IX	ISO
1BM	M3
1Am	M4
2m	M5
3m	M6
4m	M7
5m	M8

Caratteristiche

Characteristics

I paranchi a fune Misia della Serie XM sono paranchi tecnologicamente avanzati per alcuni aspetti fondamentali. I riduttori sono tutti di tipo planetario a due o tre stadi lubrificati a vita. I motori possono essere di tipo cilindrico con freno in C.C. di tipo conico su richiesta del cliente.

Gli anelli guidafune sono di tipo estremamente robusto e guidati da cuscinetti a sfera. Le funi sono di tipo zincate ad alta resistenza. I carrelli ad altezza ridotta sono dotati di due gruppi motoriduttore, con riduttori di tipo planetario con elevato rapporto di riduzione; ciò consente di utilizzare ruote senza dentatura sulle flange e quindi non esiste alcuna dentatura esposta.

The design of Misia wire rope hoist units is complemented by the use of quality components.

All gearboxes are of planetary gear type, 2 or 3 stages and lubricated for life. Motors can be supplied either with cylindrical type with disc brake or tapered rotor conical motors, depending on application or customer preference. The rope guide is manufactured using high quality materials and bearings. Ropes are of high endurance class and galvanized.

Monorail low headroom trolleys utilize our twin drive live axel design with planetary geared motors and gearboxes fitted directly onto the drive shaft of the trolley wheels eliminating the need of external gears.



ESEMPIO DI COMPOSIZIONE DEL CODICE DEL PARANCO

ABBREVIATION OF THE XM RANGE OF MISIA WIRE ROPE HOIST

XM 312 N S4 H7 A /5 a

Serie Series	Grandezza paranco Hoist size	Corsa gancio Height of lift	2a velocità di traslazione (dove richiesta) Second trolley speed (wherever requested)
		Versione: S2 - a 2 tiri di fune S4 - a 4 tiri di fune D2 - 4/2 tiri di fune tiro centrale Versions: S2 - 2 Rope falls S4 - 4 Rope falls D2 - 4/2 Rope true vertical lift	Tipo: 5 appoggiato 5C1 sospenso 3 carrello monotrave a ingombro normale 83 carrello monotrave a ingombro ridotto 53 carrello birotaia con paranco appoggiato 53C1 carrello birotaia con paranco sospenso Type: 5 foot mounted supported 5C1 foot mounted suspended 3 standard headroom monorail trolley 83 low headroom monorail trolley 53 double rail "crab" trolley with supported hoist 53C1 double rail "crab" trolley with suspended hoist
		N a 1 velocità sollevamento Normale V a 1 velocità sollevamento Veloce N Normal lifting speed (single) V Fast lifting speed (single)	2ª velocità sollevamento (dove richiesta) Second lifting speed (wherever requested)

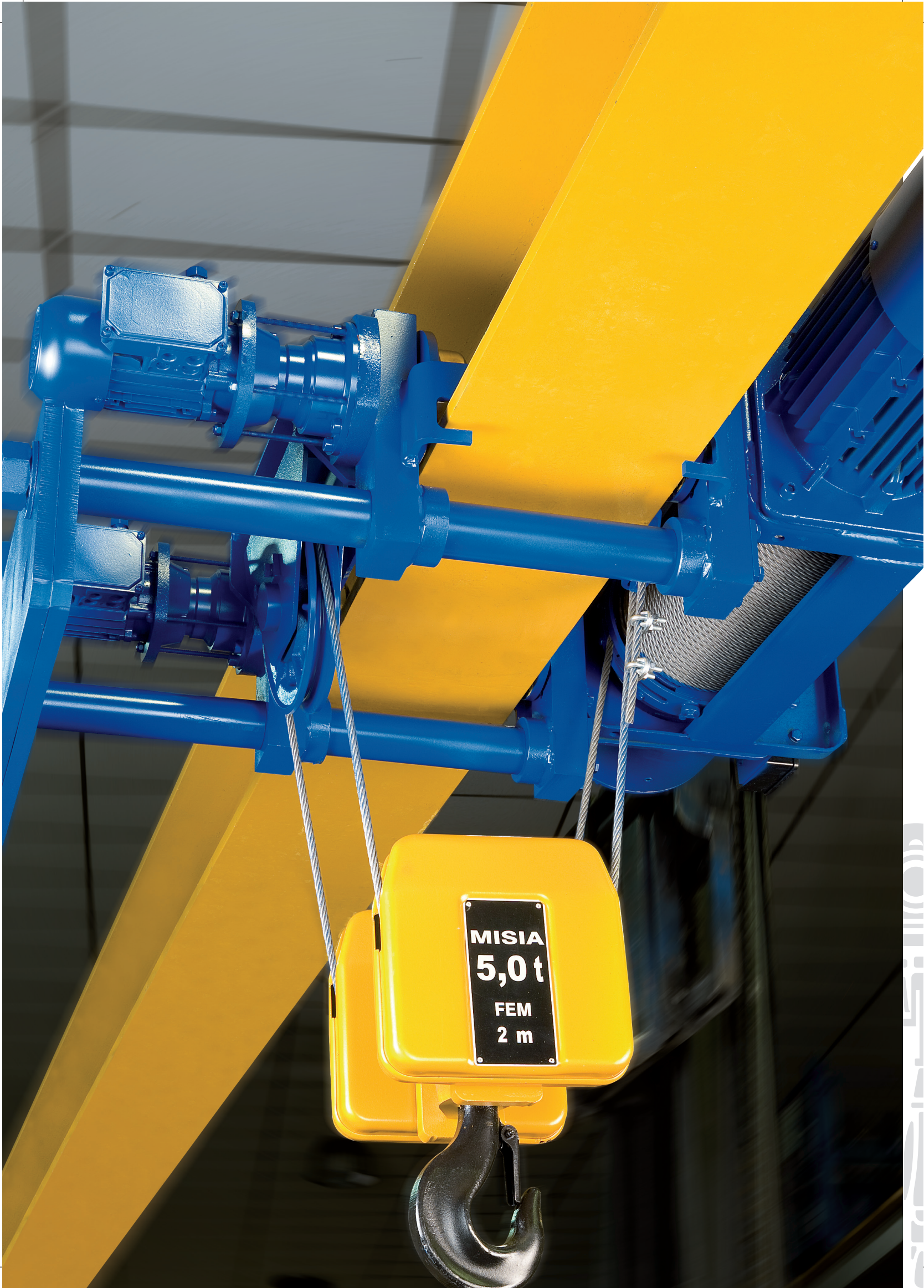

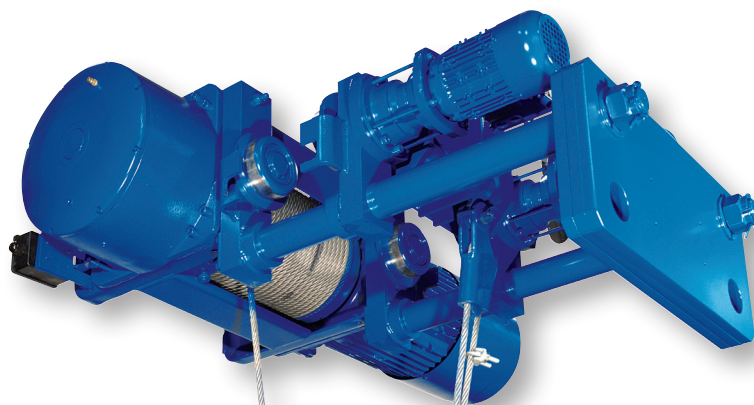
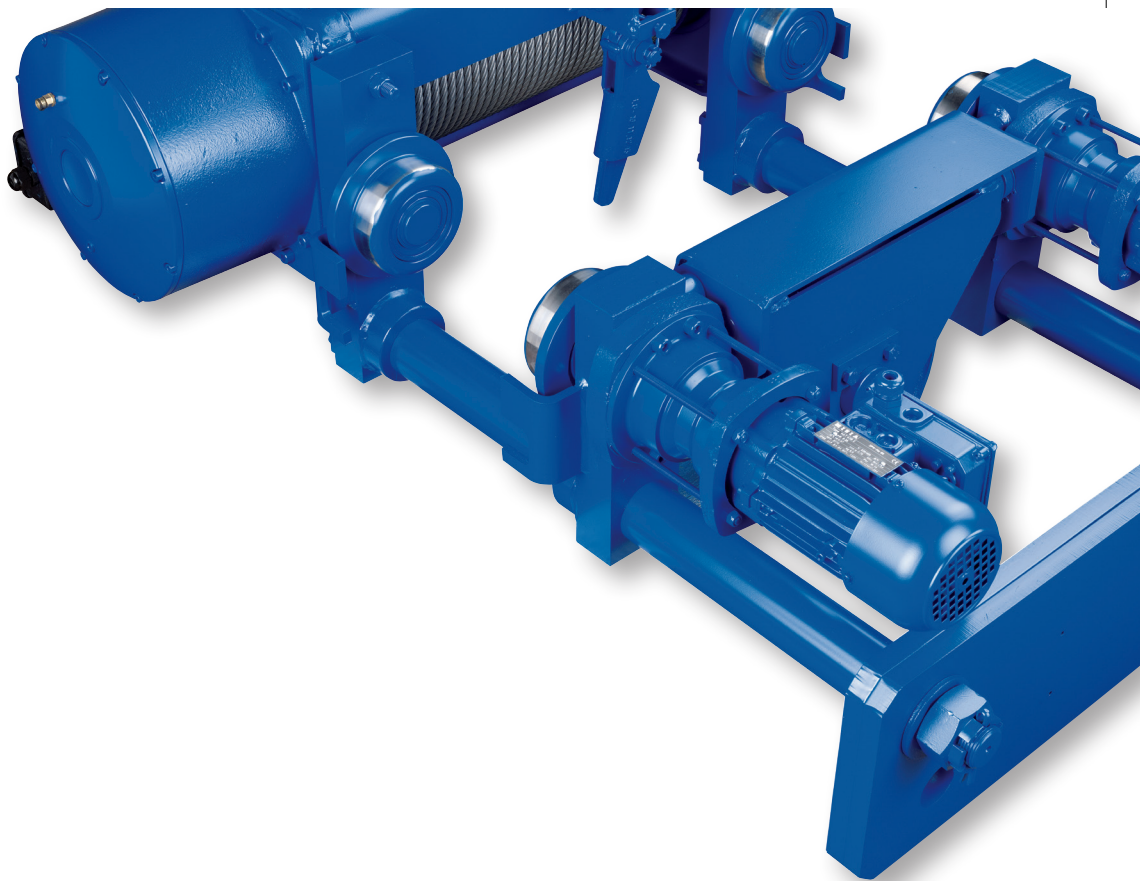

MISIA

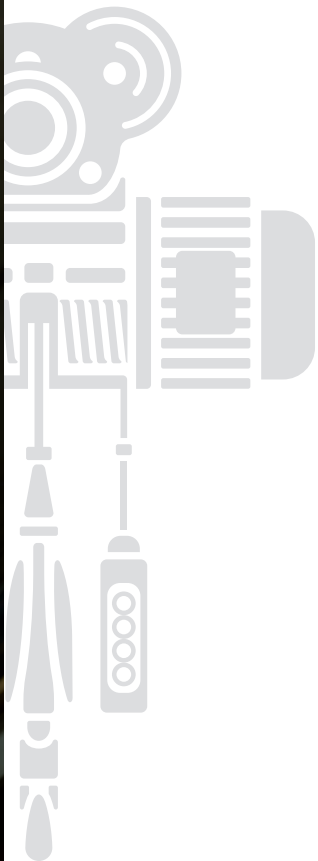

Paranchi a fune serie XM
XM series rope hoists



Paranchi a fune SERIE XM XM SERIES rope hoists

MOTORI CILINDRICI CYLINDRICAL MOTOR

CARATTERISTICHE TECNICHE - TECHNICAL DATA

Portata Capacity kg	Gruppo Groupe FEM	Paranco Hoist XM	Tiri fune Rope falls N°	Corsa gancio Hook travel H m				Velocità sollevamento / Potenze motori Lifting speed / Motor power							
				H m	H m	H m	H m	N		V		NA		VA	
								m/min	kW*	m/min	kW*	m/min	kW	m/min	kW
1000	3m	308	2/1	10	14	20	26	8	2,5	12	2,5	8/2,6	2,5/0,83	12/4	2,5/0,83
1250	3m	308	2/1	10	14	20	26	8	2,5	12	4	8/2,6	2,5/0,83	12/4	4/1,3
1600	2m	308	2/1	10	14	20	26	8	2,5	12	4	8/2,6	2,5/0,83	12/4	4/1,3
2000	3m	308	4/1	/	7	10	13	4	2,5	6	2,5	4/1,3	2,5/0,83	6/2	2,5/0,83
	3m	312	2/1	10	14	20	26	8	4	12	5	8/2,6	4/1,3	12/4	5/1,6
2500	3m	308	4/1	/	7	10	13	4	2,5	6	4	4/1,3	2,5/0,83	6/2	4/1,3
	2m	312	2/1	10	14	20	26	8	4	12	5,8	8/2,6	4/1,3	12/4	5,8/1,9
3200	2m	308	4/1	/	7	10	13	4	2,5	6	4	4/1,3	2,5/0,83	6/2	4/1,3
	2m	316	2/1	10	14	20	26	8	5	12	7	8/2,6	5/1,6	12/4	7/2,3
4000	3m	312	4/1	/	7	10	13	4	4	6	5	4/1,3	4/1,3	6/2	5/1,6
	3m	525	2/1	10	14	20	26	8	8	12	12	8/2,6	8/2,6	12/4	12/4
5000	2m	312	4/1	/	7	10	13	4	4	6	5,8	4/1,3	4/1,3	6/2	5,8/1,9
	3m	316	4/1	/	7	10	13	4	4	6	5,8	4/1,3	4/1,3	6/2	5,8/1,9
	2m	525	2/1	10	14	20	26	8	8	12	12	8/2,6	8/2,6	12/4	12/4
6300	2m	316	4/1	/	7	10	13	4	5	6	7	4/1,3	5/1,6	6/2	7/2,3
	2m	740	2/1	13	18	25	32	8	12	/	/	8/2,6	12/4	/	/
8000	3m	525	4/1	/	7	10	13	4	8	6	12	4/1,3	8/2,6	6/2	12/4
	1Am	740	2/1	13	18	25	32	8	12	/	/	8/2,6	12/4	/	/
	2m	750	2/1	13	18	25	32	/	/	8	12,5	/	/	8/2,6	12/4
10000	2m	525	4/1	/	7	10	13	4	8	6	12	4/1,3	8/2,6	6/2	12/4
	1Am	750	2/1	13	18	25	32	/	/	8	15	/	/	8/2,6	15/5
	2m	950	2/1	20	32	48	/	7,5	16	/	/	7,5/2,5	16/5,3	9/3	18/6
12500	2m	740	4/1	6,5	9	12,5	16	4	12	/	/	4/1,3	12/4	/	/
	1Am	963	2/1	20	32	48	/	7,5	18	/	/	7,5/2,5	18/6	/	/
16000	1Am	740	4/1	6,5	9	12,5	16	4	12	/	/	4/1,3	12/4	/	/
	2m	750	4/1	6,5	9	12,5	16	/	/	4	12	/	/	4/1,3	12/4
	3m	950	4/1	10	16	24	/	4,5	16	6	20	4,5/1,5	16/5,3	6/2	20/6,5
	1Am	980	2/1	20	32	48	/	7,5	24	/	/	/	/	/	/
20000	1Am	750	4/1	6,5	9	12,5	16	/	/	4	15	/	/	4/1,5	15/5
	2m	950	4/1	10	16	24	/	4,5	18	6	24	4,5/1,5	18/6	6/2	22/7,3
	2m	1100	2/1	20	24	30	44	4,5	18	/	/	4,5/1,5	18/6	/	/
25000	1Am	963	4/1	10	16	24	/	3,8	18	/	/	3,8/1,3	18/6	/	/
	1Am	1125	2/1	20	24	30	44	4,6	24	/	/	4,5/1,5	22/7,3	/	/
32000	1Am	980	4/1	10	16	24	/	3,8	24	/	/	/	/	/	/
40000	2m	1100	4/1	10	12	15	22	2,3	18	/	/	2,3/0,6	18/6	/	/
50000	1Am	1125	4/1	10	12	15	22	2,3	24	/	/	2,3/0,6	22/7,3	/	/

* Motori utilizzabili con inverter / Motors suitable also with inverter



Paranchi a fune SERIE XM XM SERIES rope hoists

MOTORI CONICI CONICAL MOTOR

CARATTERISTICHE TECNICHE - TECHNICAL DATA

Portata Capacity kg	Gruppo Groupe FEM	Paranco Hoist XM	Tiri fune Rope falls N°	Corsa gancio Hook travel				Velocità sollevamento / Potenze motori Lifting speed / Motor power							
				H m	H m	H m	H m	N		V		NA		VA	
								m/min	kW	m/min	kW	m/min	kW	m/min	kW
1000	3m	308	2/1	10	14	20	26	8	2,5	12	2,5	8/2,6	3/1	12/4	3/1
1250	3m	308	2/1	10	14	20	26	8	2,5	12	4,5	8/2,6	3/1	12/4	3/1
1600	2m	308	2/1	10	14	20	26	8	2,5	12	4,5	8/2,6	3/1	12/4	4,5/1,5
2000	3m	308	4/1	/	7	10	13	4	2,5	6	2,5	4/1,3	3/1	6/2	3/1
	3m	312	2/1	10	14	20	26	8	4,5	12	4,5	8/2,6	3/1	12/4	4,5/1,5
2500	3m	308	4/1	/	7	10	13	4	2,5	6	4,5	4/1,3	3/1	6/2	4,5/1,5
	2m	312	2/1	10	14	20	26	8	4,5	12	5,5	8/2,6	4,5/1,5	12/2	6/1
3200	2m	308	4/1	/	7	10	13	4	2,5	6	4,5	4/1,3	3/1	6/2	4,5/1,5
	2m	316	2/1	10	14	20	26	8	4,5	/	/	8/2,6	4,5/1,5	/	/
4000	3m	312	4/1	/	7	10	13	4	4,5	6	4,5	4/1,3	4,5/1,5	6/2	4,5/1,5
	3m	525	2/1	10	14	20	26	8	7,5	12	12	8/1,3	8/1,3	12/2	12,5/1,7
5000	2m	312	4/1	/	7	10	13	4	4,5	6	5,5	4/1,3	4,5/1,5	6/1	6/1
	3m	316	4/1	/	7	10	13	4	4,5	6	5,5	4/1,3	4,5/1,5	6/1	6/1
	2m	525	2/1	10	14	20	26	8	7,5	6	12	8/1,3	8/1,3	12/2	12,5/1,7
6300	2m	316	4/1	/	7	10	13	4	4,5	/	/	4/1,3	4,5/1,5	/	/
	2m	740	2/1	13	18	25	32	8	12,5	/	/	8/2	13/3	/	/
8000	3m	525	4/1	/	7	10	13	4	7,5	6	12	4/0,7	8/1,3	6/1	12,5/1,7
	1Am	740	2/1	13	18	25	32	8	12	/	/	8/2	13/3	/	/
	2m	750	2/1	13	18	25	32	5	12,5	/	/	5/1,2	13/3	8/1,3	12,5/2,0
10000	2m	525	4/1	/	7	10	13	4	7,5	6	12	4/0,7	8/1,3	6/1	12,5/1,7
	1Am	750	2/1	13	18	25	32	5	12,5	/	/	5/1,2	13/3	8/1,3	15/2,5
	2m	950	2/1	20	32	48	/	6	12,5	/	/	6/1,5	13/3	/	/
12500	2m	740	4/1	6,5	9	12,5	16	4	12,5	/	/	4/1	13/3	/	/
	1Am	963	2/1	20	32	48	/	5	12,5	/	/	5/1,2	13/3	/	/
16000	1Am	740	4/1	6,5	9	12,5	16	4	12,5	/	/	4/1	13/3	/	/
	2m	750	4/1	6,5	9	12,5	16	2,5	12,5	/	/	2,5/0,6	13/3	4/1	13/3
	3m	950	4/1	10	16	24	/	3	12,5	/	/	3/0,75	13/3	/	/
	1Am	980	2/1	20	32	48	/	/	/	/	/	5/1,2	16/4	/	/
20000	1Am	750	4/1	6,5	9	13	16	2,5	12,5	/	/	2,5/0,6	13/3	4/0,6	15/2,5
	2m	950	4/1	10	16	24	/	3	12,5	/	/	3/0,75	13/3	/	/
	2m	1100	2/1	20	24	30	44	3	12,5	/	/	3/0,75	13/3	/	/
25000	1Am	963	4/1	10	16	24	/	2,5	12,5	/	/	2,5/0,6	13/3	/	/
	1Am	1125	2/1	20	24	30	44	/	/	/	/	3/0,75	16/4	/	/
32000	1Am	980	4/1	10	16	24	/	/	/	/	/	2,5/0,6	16/4	/	/
40000	2m	1100	4/1	10	12	15	22	/	/	/	/	1,5/0,37	13/3	/	/
50000	1Am	1125	4/1	10	12	15	22	/	/	/	/	1,5/0,37	16/4	/	/



Paranchi a fune SERIE XM XM SERIES rope hoists

CARRELLI
TROLLEYS

CARATTERISTICHE TECNICHE - TECHNICAL DATA

Portata Capacity	Gruppo Groupe	Paranco Hoist	Tiri funi Rope falls	Velocità carrelli e potenze motori Trolleys speeds and motor power																											
				Monotrave Monorail								Birotaia Birail																			
				Tipo: 3-43 Type: 3-43				Tipo: 83 Type: 83				Tipo: 53-53C1 Type: 53-53C1																			
				m/min	kW *	m/min	kW	m/min	kW *	m/min	kW	m/min	kW *	m/min	kW	m/min	kW	m/min	kW												
1000	3m	308	2/1	18	0,37	18/6	0,37/0,12	20	2x0,24	20/5	2x0,24/0,06	0,37	0,37/0,12	0,37	0,37/0,12																
1250	3m	308	2/1																												
1600	2m	308	2/1																												
2000	3m	308	4/1																												
	3m	312	2/1																												
2500	3m	308	4/1																												
	2m	312	2/1																												
3200	2m	308	4/1																												
	2m	316	2/1																												
4000	3m	312	4/1																												
	3m	525	2/1																												
5000	2m	312	4/1																												
	3m	316	4/1																												
6300	2m	525	2/1																												
	2m	740	2/1																												
8000	3m	525	4/1															0,55	0,55/0,18	20	2x0,30	20/5	2x0,30/0,07	16	0,55	16/5,3	0,55	20	0,55/0,18	20/6,5	0,55/0,18
	1Am	740	2/1																												
	2m	750	2/1																												
10000	2m	525	4/1	2x0,37	2x0,37/0,12	20	2x0,30	20/5	2x0,30/0,07	0,75	0,75/0,25	1,1	1,1/0,37																		
	1Am	750	2/1																												
12500	2m	950	2/1	2x0,55	2x0,55/0,18	/	/	/	/	1,1	1,1/0,37	1,5	1,5/0,55																		
	2m	740	4/1																												
	1Am	963	2/1																												
16000	1Am	740	4/1	20	2x0,75	20/6,5	2x0,75/0,25	/	/	/	/	2x1,1	2x1,1/0,37	2x1,1	2x1,1/0,37																
	2m	750	4/1																												
	3m	950	4/1																												
	1Am	980	2/1																												
20000	1Am	750	4/1	/	/	/	/	/	/	2x1,5	2x1,5/0,55	2x1,5	2x1,5/0,55																		
	2m	950	4/1																												
	2m	1100	2/1																												
25000	1Am	963	4/1	/	/	/	/	/	/	2x1,5	2x1,5/0,55	2x1,5	2x1,5/0,55																		
	1Am	1125	2/1																												
32000	1Am	980	4/1	20	2x1,1	20/6,5	2x1,1/0,37					2x1,1	2x1,1/0,37	2x1,1	2x1,1/0,37																
40000	2m	1100	4/1	/	/	/	/					2x1,5	2x1,5/0,55	2x1,5	2x1,5/0,55																
50000	1Am	1125	4/1	/	/	/	/					2x1,5	2x1,5/0,55	2x1,5	2x1,5/0,55																

* Motori utilizzabili con inverter / Motors suitable also with inverter





Paranchi standard SERIE XM
XM SERIES standard hoists

XM 308 / 312 / 316 / 525

Portata Capacity 1÷5 t

S2 2 TIRI DI FUNE (2/1) - 2 ROPE FALLS (2/1)

Fig. 5 APPOGGIATO - SUPPORTED

Fig. 5C1 SOSPEO - SUSPENDED



S2

Fig. 5

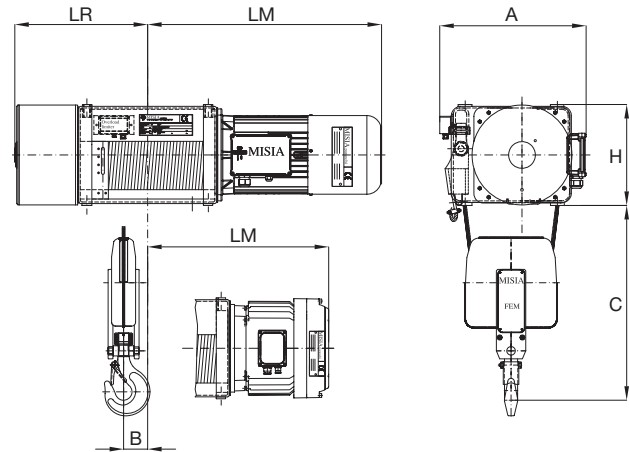

S2 - XM 308 / 312 / 316 / 525

Portata Capacity 1÷5 t

Paranco Hoist	Portata Capacity	Corsa gancio Hook travel	Dimensioni Dimensions					Motori cilindrici Cylindrical motors				Motori conici Conical motors				Peso Weight
			C mm	H mm	A mm	B mm	LR mm	Speed m/min	LM mm	Speed m/min	LM mm	Speed m/min	LM mm	LM mm	Kg	
308	1,6	10	570	325	490	91	400	N	730	V	730	N	590	V	640	210
		14				154	460		790		645		702		300	
		20				244	550		880		735		810		320	
		26				337	645	NA	975	VA	975	NA	830	VA	910	335
312	2,5	10	640	325	490	90	470	N	750	V	830	N	640	V	640	350
		14				155	535		815		895		705		370	
		20				258	640		920		1000		810		390	
		26				358	740	NA	1020	VA	1100	NA	910	VA	910	415
316	3,2	10	640	325	500	90	470	N	770	V	830	N	640	/	/	375
		14				155	535		835		895		705		400	
		20				258	640		940		1000		810		425	
		26				358	740	NA	1040	VA	1100	NA	910	/	/	450
525	5	10	730	380	530	90	500	N	840	V	900	N	690	V	740	460
		14				157	565		905		965		805		480	
		20				260	670		1010		1070		910		520	
		26				360	770	NA	1110	VA	1170	NA	960	VA	1010	560

N - V - NA - VA = velocità di sollevamento (vedi pagine 18-19) / lifting speeds (see pages 18-19)



Paranchi standard SERIE XM XM SERIES standard hoists

XM 740 / 750 / 950 / 963 / 980 / 1100 / 1125 Portata Capacity 6,3÷25 t

S2 2 TIRI DI FUNE (2/1) - 2 ROPE FALLS (2/1)

Fig. 5 APPOGGIATO - SUPPORTED

Fig. 5C1 SOSPESO - SUSPENDED



S2

Fig. 5

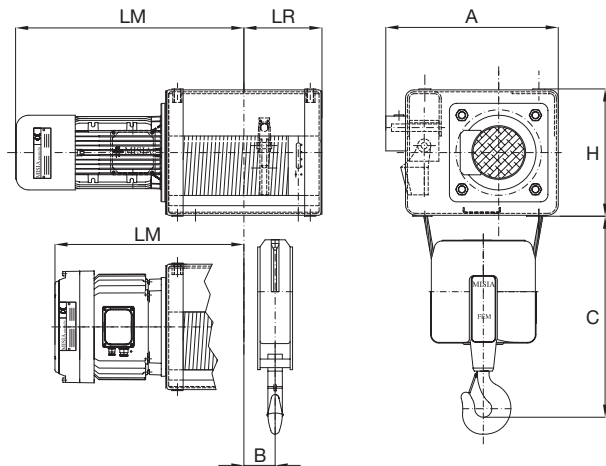

S2 - XM 740 / 750 / 950 / 963 / 980 / 1100 / 1125

Portata Capacity 6,3÷25 t

Paranco Hoist	Portata Capacity	Corsa gancio Hook travel	Dimensioni Dimensions					Motori cilindrici Cylindrical motors				Motori conici Conical motors				Peso Weight
			C mm	H mm	A mm	B mm	LR mm	Speed m/min	LM mm	Speed m/min	LM mm	Speed m/min	LM mm	Speed m/min	LM mm	
740	8	13	840	530	740	130	325	N	950	/	/	N	790	/	/	840
		160				405	1030		870				880			
		268				510	1135		975				930			
		375				620	1245		1080				980			
750	10	13	840	530	740	130	325	N	950	/	/	N	790	V	810	850
		160				405	1030		870				890			
		268				510	1135		975				995			
		375				620	1245		1080				V A	1105	980	
950	10	20	1100	625	800	230	480	N	1200	/	/	N	940	V	940	1270
		438				690	1460		1150				1150			
		688				940	1660		1400				V A	1400	1600	
		20				480	N		1200				940	1270		
963	12,5	20	1100	625	800	230	480	N	1200	/	/	N	940	/	/	1270
		438				690	1460		1150				1420			
		688				940	1660		1400				1600			
		20				480	N		1200				960			1920
980	16	20	1150	625	800	230	480	N	1200	/	/	N	960	/	/	1920
		438				690	1460		1170				2070			
		688				940	1660		1420				2250			
		20				610	/		/				/			/
305	705	1245	2430													
400	825	1365	2690													
520	1080	1620	3300													
1100*	20	20	1330	810	1130	305	610	/	/	/	/	N	1150	/	/	2350
		400				705	1245						2430			
		520				825	1365						2690			
		775				1080	1620						3300			
1125*	25	20	1330	810	1130	305	610	/	/	/	/	N	1150	/	/	2350
		400				705	1245						2430			
		520				825	1365						2690			
		775				1080	1620						3300			

* Solo in versione appoggiata / Only supported version

N - V - N A - V A = velocità di sollevamento (vedi pagine 18-19) / lifting speeds (see pages 18-19)



Paranchi standard SERIE XM
XM SERIES standard hoists

XM 308 / 312 / 316 / 525

Portata Capacity 2÷10 t

S4 4 TIRI DI FUNE (4/1) - 4 ROPE FALLS (4/1)

Fig. 5 APPOGGIATO - SUPPORTED

Fig. 5C1 SOSPESO - SUSPENDED



S4

Fig. 5

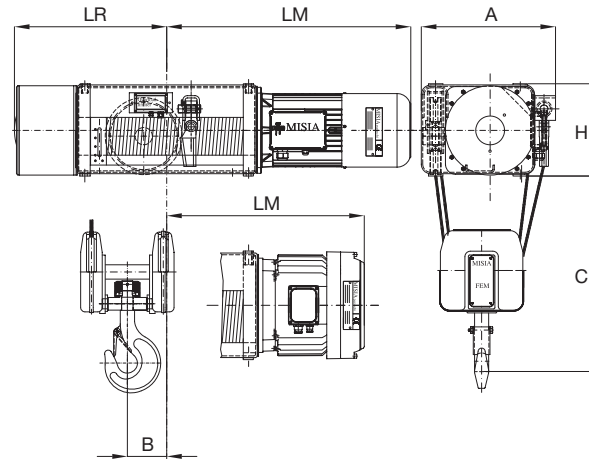

S4 - XM 308 / 312 / 316 / 525

Portata Capacity 2÷10 t

Paranco Hoist	Portata Capacity	Corsa gancio Hook travel	Dimensioni Dimensions					Motori cilindrici Cylindrical motors				Motori conici Conical motors				Peso Weight
			C mm	H mm	A mm	B mm	LR mm	Speed m/min	LM mm	Speed m/min	LM mm	Speed m/min	LM mm	Speed m/min	LM mm	
308	3,2	7	520	325	490	132	460	N	790	V	790	N	645	V	702	320
		222				550	880		880		810		340			
		13				314	645	NA	975	VA	975	NA	830	VA	910	360
312	5	7	590	325	490	137	535	N	815	V	895	N	705	V	705	390
		240				640	920		1000		810		810		420	
		13				340	740	NA	1020	VA	1100	NA	910	VA	910	450
316	6,3	7	640	325	500	137	535	N	835	V	895	N	705	/	/	480
		240				640	940		1000		810		810		510	
		13				340	740	NA	1040	VA	1100	NA	910	VA	910	550
525	10	7	730	380	530	133	565	N	905	V	965	N	750	V	805	580
		236				670	1010		1070		860		860		620	
		13				336	770	NA	1110	VA	1170	NA	960	VA	1010	660

N - V - NA - VA = velocità di sollevamento (vedi pagine 18-19) / lifting speeds (see pages 18-19)



Paranchi standard SERIE XM XM SERIES standard hoists

XM 740 / 750 / 950 / 963 / 980 / 1100 / 1125 Portata Capacity 12,5÷50 t

S4 4 TIRI DI FUNE (4/1) - 4 ROPE FALLS (4/1)

Fig. 5 APPOGGIATO - SUPPORTED

Fig. 5C1 SOSPEO - SUSPENDED



S4

Fig. 5

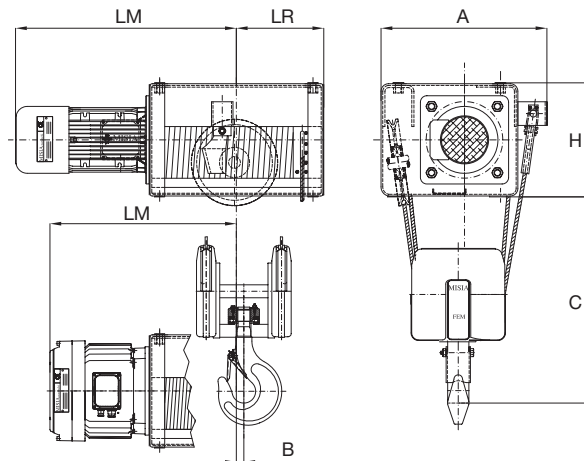

S4 - XM 740 / 750 / 950 / 963 / 980 / 1100 / 1125

Portata Capacity 12,5÷50 t

Paranco Hoist	Portata Capacity	Corsa gancio Hook travel	Dimensioni Dimensions					Motori cilindrici Cylindrical motors				Motori conici Conical motors				Peso Weight	
			C mm	H mm	A mm	B mm	LR mm	Speed m/min	LM mm	Speed m/min	LM mm	Speed m/min	LM mm	Speed m/min	LM mm		Kg
740	16	6,5	825	530	740	35	325	N	950	/	/	N	790	/	/	650	
		9				115	405		1030				870				690
		12,5				223	510		1135				975				740
		16				330	620		1245				1080				790
750	20	6,5	880	530	740	35	325	N	950	/	/	N	790	V	810	650	
		9				115	405		1030				870		690		
		12,5				223	510		1135				975		740		
		16				330	620		1245				1080		790		
950	20	10	1000	625	860	130	480	N	1200	V	1240	N	940	V	940	1070	
		16				338	690		1460		1150		1220				
		24				588	940		1660		1400		1400				
		10				130	480		1200		940		1070				
963	25	16	1000	625	860	338	690	N	1460	/	/	N	1150	/	/	1220	
		24				588	940		1660				1400			1400	
		10				130	480		1200				940			1070	
		16				338	690		1460				1150			1220	
980	32	10	1180	625	860	130	480	N	1200	/	/	N	940	/	/	1090	
		16				338	690		1460				1150			1240	
		24				588	940		1660				1400			1420	
		10				193	610		1150				1150			2700	
1100*	40	12	1170	810	1140	285	705	/	/	/	/	N	1245	/	/	2800	
		15				405	825						1365			3060	
		22				660	1080						1620			3700	
		10				193	610						1150			1150	2700
1125*	50	12	1170	810	1140	285	705	/	/	/	/	N	1245	/	/	2800	
		15				405	825						1365			3060	
		22				660	1080						1620			3700	
		10				193	610						1150			1150	2700

* Solo in versione appoggiata / Only supported version

N - V - N A - V A = velocità di sollevamento (vedi pagine 18-19) / lifting speeds (see pages 18-19)



Paranchi standard SERIE XM
XM SERIES standard hoists

XM 308 / 312 / 316 / 525

Portata Capacity 1÷5 t

S2 2 TIRI DI FUNE (2/1) - 2 ROPE FALLS (2/1)

Fig. 3 A INGOMBRO NORMALE - NORMAL HEADROOM



S2

Fig. 3

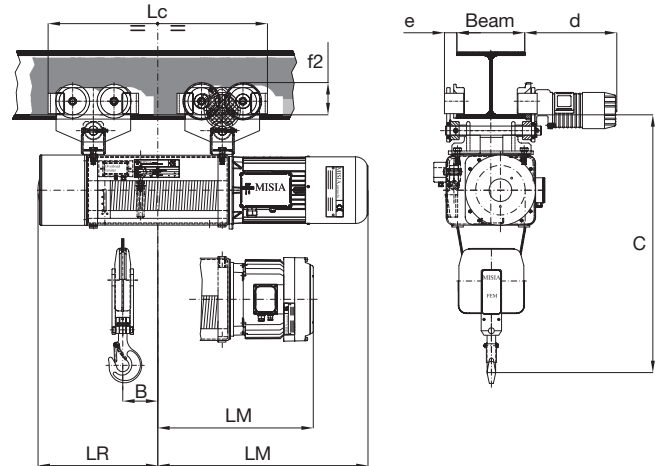

S2 - XM 308 / 312 / 316 / 525

Portata Capacity 1÷5 t

Paranco Hoist	Portata Capacity	Corsa gancio Hook travel	Dimensioni Dimensions							Motori cilindrici Cylindrical motors				Motori conici Conical motors				Peso Weight
			XM	t-max	m	C mm	d mm	e mm	Lc mm	LR mm	B mm	f2 mm	Speed m/min	LM mm	Speed m/min	LM mm	Speed n/min	
308	1,6	10	1080	410	60	795	400	91	145	N	730	V	730	N	590	V	640	290
		920				460	154	790			645		702		300			
		1100				550	244	880			735		810		320			
		1285				645	337	975			830		910		335			
312	2,5	10	1140	410	60	840	470	90	145	N	750	V	830	N	640	V	640	350
		940				535	155	815			705		705		370			
		1175				640	258	920			810		810		390			
		1375				740	358	1020			910		910		415			
316	3,2	10	1140	410	60	840	470	90	145	N	770	V	830	N	640	/	/	375
		970				535	155	835			705		400					
		1175				640	258	940			810		425					
		1375				740	358	1040			910		450					
525	5	10	1180	410	60	855	500	90	145	N	840	V	900	N	690	V	740	460
		990				565	158	905			750		805		480			
		1175				670	260	1010			860		910		520			
		1395				770	360	1110			960		1010		560			

N - V - N A - V A = velocità di sollevamento (vedi pagine 18-19) / lifting speeds (see pages 18-19)



Paranchi standard SERIE XM
XM SERIES standard hoists

XM 740 / 750 / 950 / 963

Portata Capacity 6,3÷16 t

S2 2 TIRI DI FUNE (2/1) - 2 ROPE FALLS (2/1)

Fig. 3 A INGOMBRO NORMALE - NORMAL HEADROOM



S2

Fig. 3

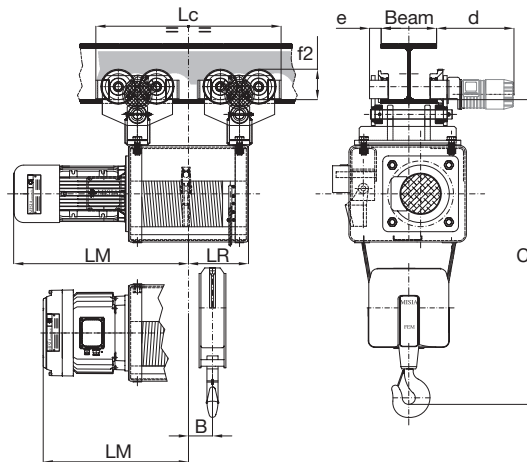

S2 - XM 740 / 750 / 950 / 963

Portata Capacity 6,3÷16 t

Paranco Hoist	Portata Capacity	Corsa gancio Hook travel	Dimensioni Dimensions							Motori cilindrici Cylindrical motors				Motori conici Conical motors				Peso Weight																			
			C mm	d mm	e mm	Lc mm	LR mm	B mm	f2 mm	Speed m/min	LM mm	Speed m/min	LM mm	Speed n/min	LM mm	Speed n/min	LM mm		Kg																		
XM	t-max	m	C	d	e	Lc	LR	B	f2	Speed m/min	LM mm	Speed m/min	LM mm	Speed n/min	LM mm	Speed n/min	LM mm	Kg																			
																			740	8	13	1630	430	70	1005	325	130	165	N	950	/	/	N	790	/	/	840
																					18				1165	405	160		870	880							
																					25				1380	510	268		975	930							
32	1595	620	375	1080	980																																
750	10	13	1650	430	70	1005	325	130	165	N	950	/	/	N	790	V	810	850																			
		18				1165	405	160		870	890																										
		25				1380	510	268		975	930																										
		32				1595	620	375		1080	VA			1105	980																						
950	10	20	1990	430	70	1290	480	230	165	N	1200	V	1240	N	940	V	940	1270																			
		32				1705	690	438		1500	1150	1420																									
		48				2205	940	688		1700	1400	VA	1400	1600																							
963	12,5	20	1990	430	85	1290	480	230	165	N	1200	V	1240	N	940	/	/	1270																			
		32				1705	690	438		1500	1150	1420																									
		48				2205	970	688		1700	1400	1600																									
980	16	20	2150	300	150	1440	480	230	235	N	1200	/	/	N	960	/	/	1920																			
		32				1855	690	438		1170	2070																										
		48				2355	940	688		1420	2250																										

N - V - N A - V A = velocità di sollevamento (vedi pagine 18-19) / lifting speeds (see pages 18-19)



Paranchi standard SERIE XM
XM SERIES standard hoists

XM 308 / 312 / 316 / 525

Portata Capacity 2÷10 t

S4 4 TIRI DI FUNE (4/1) - 4 ROPE FALLS (4/1)

Fig. 3 A INGOMBRO NORMALE - NORMAL HEADROOM



S4

Fig. 3

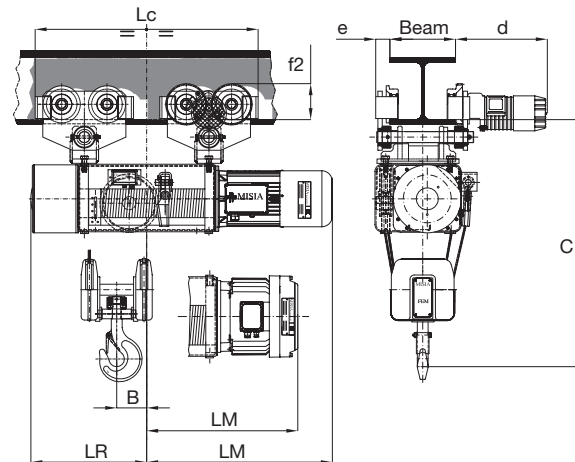

S4 - XM 308 / 312 / 316 / 525

Portata Capacity 2÷10 t

Paranco Hoist	Portata Capacity	Corsa gancio Hook travel	Dimensioni Dimensions							Motori cilindrici Cylindrical motors				Motori conici Conical motors				Peso Weight
			XM	t-max	m	C mm	d mm	e mm	Lc mm	LR mm	B mm	f2 mm	Speed m/min	LM mm	Speed m/min	LM mm	Speed n/min	
308	3,2	7	1020	410	60	920	460	132	145	N	790	V	790	N	645	V	702	320
		10				1100	550	222			880		735		810		340	
		13				1285	645	314			975		830		910		360	
312	5	7	1120	410	60	970	535	137	145	N	815	V	895	N	705	V	705	390
		10				1175	640	240			920		810		810		420	
		13				1375	740	340			1020		910		910		450	
316	6,3	7	1140	430	70	890	535	137	165	N	835	V	895	N	705	/	/	480
		10				1020	640	240			940		810		510			
		13				1225	740	340			1040		910		550			
525	10	7	1290	430	70	1040	565	133	165	N	905	V	965	N	750	V	805	580
		10				1225	670	236			1010		860		910		620	
		13				1445	770	336			1110		960		1010		660	

N - V - N A - V A = velocità di sollevamento (vedi pagine 18-19) / lifting speeds (see pages 18-19)



Paranchi standard SERIE XM
XM SERIES standard hoists

XM 740 / 750 / 950 / 963

Portata Capacity 12,5÷32 t

S4 4 TIRI DI FUNE (4/1) - 4 ROPE FALLS (4/1)

Fig. 3 A INGOMBRO NORMALE - NORMAL HEADROOM

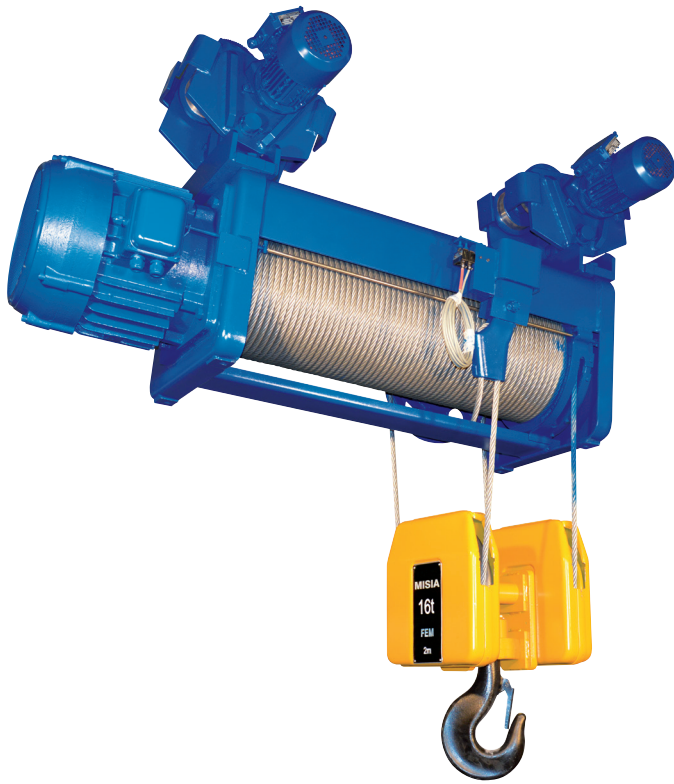

S4

Fig. 3

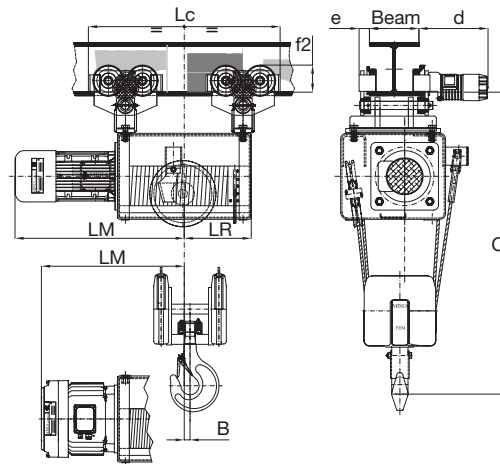

S4 - XM 740 / 750 / 950 / 963

Portata Capacity 12,5÷32 t

Paranco Hoist	Portata Capacity	Corsa gancio Hook travel	Dimensioni Dimensions							Motori cilindrici Cylindrical motors				Motori conici Conical motors				Peso Weight																			
			C mm	d mm	e mm	Lc mm	LR mm	B mm	f2 mm	Speed m/min	LM mm	Speed m/min	LM mm	Speed n/min	LM mm	Speed n/min	LM mm		Kg																		
XM	t-max	m	C	d	e	Lc	LR	B	f2	Speed m/min	LM mm	Speed m/min	LM mm	Speed n/min	LM mm	Speed n/min	LM mm	Kg																			
																			740	16	6,5	1600	430	85	1005	325	35	165	N	950	/	/	N	790	/	/	900
																					9				1165	405	115		870	940							
																					12,5				1380	510	223		975	990							
16	1595	620	330	1245	NA	1080	NA	1040																													
750	20	9	1740	300	150	1315	405	115	235	N	1030	/	/	N	870	V	890	1590																			
		12,5				1530	510	223		975	995			1640																							
		16				1893	620	330		1245	NA			1080	VA	1105	1690																				
950	20	10	1960	300	150	1440	480	130	235	N	1200	V	1240	N	940	V	940	1970																			
		16				1855	690	338		1500	1150	1150	2120																								
		24				2355	940	588		1700	1400	1400	2300																								
963	25	10	1960	300	150	1440	480	130	235	N	1200	/	/	N	940	/	/	1970																			
		16				1855	690	338		1150	2120																										
		24				2355	940	588		1400	2300																										
980	32	10	2040	300	150	1440	480	130	235	N	1200	/	/	N	940	/	/	1990																			
		16				1855	690	338		1150	2140																										
		24				2355	940	588		1400	2320																										

N - V - N A - V A = velocità di sollevamento (vedi pagine 18-19) / lifting speeds (see pages 18-19)



Paranchi standard SERIE XM XM SERIES standard hoists

XM 308 / 312 / 316 / 525

S2 2 TIRI DI FUNE (2/1) - 2 ROPE FALLS (2/1)

Fig. 83 CARRELLO MONOTRAVE A INGOMBRO RIDOTTO
MONORAIL TROLLEY LOW HEADROOM



S2

Fig. 83

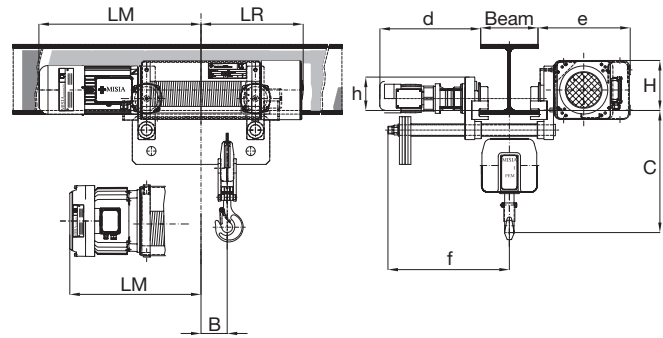

S2 - XM 308 / 312 / 316 / 525

Paranco Hoist	Portata Capacity	Corsa gancio Hook travel	Dimensioni Dimensions								Motori cilindrici Cylindrical motors				Motori conici Conical motors				Peso Weight
			XM	t-max	m	C mm	H mm	h mm	d mm	e mm	f mm	LR mm	B mm	Speed m/min	LM mm	Speed m/min	LM mm	Speed m/min	
308	1,6	10	700	240	140	430	470	410	400	91	N	730	V	730	N	530	V	580	310
		460							154	790		790		590		640		340	
		550							244	880		880		680		730		380	
		645							337	NA		975		VA		975		NA	775
		470							90	N	750	V	830	N	600	V	640	450	
535	155	815	895	665	705	470													
640	258	920	1000	770	810	510													
740	358	NA	1020	VA	1100	NA	870	VA	910		560								
316	3,2	10	680	240	140	430	470	410	470	90	N	770	V	830	N	640	/	/	500
		535							155	835		895		705		520			
		640							258	940		1000		810		590			
		740							358	NA		1040		VA		1100		NA	910
		500							90	N	840	V	900	N	650	V	740	610	
565	157	905	965	715	805	660													
670	260	1010	1070	820	910	740													
770	360	NA	1110	VA	1170	NA	920	VA	1010		820								

N - V - NA - VA = velocità di sollevamento (vedi pagine 18-19) / lifting speeds (see pages 18-19)

Nota:

- 1) Per le ali travi superiori a quelle indicate, la quota "C" (ingombro gancio) aumenta di 12 mm ogni 10 mm di larghezza ala trave.
- 2) La quota "f" indicata è valida per ala trave di 300 mm; con ala diversa, aumenta o diminuisce di metà della differenza ala trave.

Note:

- 1) For beam sizes wider than those shown, the "C" dimension (encumbrance of the hook) increases of 12 mm every 10 mm of wider beam size.
- 2) The dimension "f" shown is valid for beam size 300 mm; with different beam size it increases or decreases of half of the difference of the beam size.



Paranchi standard SERIE XM XM SERIES standard hoists

XM 308 / 312 / 316 / 525

S4 4 TIRI DI FUNE (4/1) - 4 ROPE FALLS (4/1)

Fig. 83 CARRELLO MONOTRAVE A INGOMBRO RIDOTTO
MONORAIL TROLLEY LOW HEADROOM



S4

Fig. 83

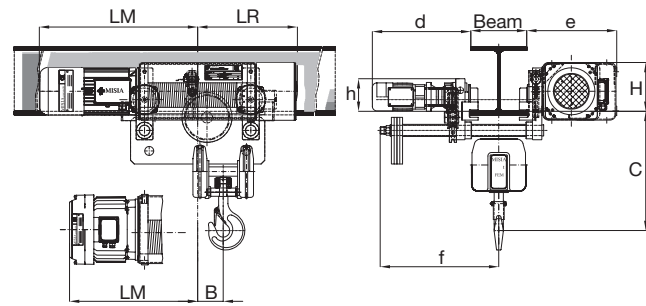

S4 - XM 308 / 312 / 316 / 525

Paranco Hoist	Portata Capacity	Corsa gancio Hook travel	Dimensioni Dimensions								Motori cilindrici Cylindrical motors				Motori conici Conical motors				Peso Weight
			XM	t-max	m	C mm	H mm	h mm	d mm	e mm	f mm	LR mm	B mm	Speed m/min	LM mm	Speed m/min	LM mm	Speed m/min	
308	3,2	7	680	245	140	430	470	410	460	132	N	790	V	790	N	590	V	640	360
		550							222	880		880		680		730		400	
		13							645	314	NA	975	VA	975	NA	775	VA	825	480
312	5	7	620	245	140	475	470	440	535	137	N	815	V	895	N	665	V	705	490
		640							240	920		1000		770		810		540	
		13							740	340	NA	1020	VA	1100	NA	870	VA	910	590
316	6,3	7	640	245	160	475	470	440	535	137	N	895	V	895	N	705	/	/	500
		640							240	1000		1000		810		/		550	
		13							740	340	NA	1100	VA	1100	NA	910	/	600	
525	10	7	700	305	175	535	570	530	565	133	N	905	V	965	N	715	V	805	660
		670							236	1010		1070		820		910		750	
		13							770	336	NA	1110	VA	1170	NA	920	VA	1010	840

N - V - NA - VA = velocità di sollevamento (vedi pagine 18-19) / lifting speeds (see pages 18-19)

Nota:

- 1) Per le ali travi superiori a quelle indicate, la quota "C" (ingombro gancio) aumenta di 12 mm ogni 10 mm di larghezza ala trave.
- 2) La quota "f" indicata è valida per ala trave di 300 mm; con ala diversa, aumenta o diminuisce di metà della differenza ala trave.

Note:

- 1) For beam sizes wider than those shown, the "C" dimension (encumbrance of the hook) increases of 12 mm every 10 mm of wider beam size.
- 2) The dimension "f" shown is valid for beam size 300 mm; with different beam size it increases or decreases of half of the difference of the beam size.



Paranchi standard SERIE XM XM SERIES standard hoists



XM 308 / 312 / 316 / 525

S2 2 TIRI DI FUNE (2/1) - 2 ROPE FALLS (2/1)

Fig. 53 CARRELLO BIROTAIA CON PARANCO APPOGGIATO
BIRAIL TROLLEY HOIST SUPPORTED

Fig. 53C1 CARRELLO BIROTAIA CON PARANCO SOSPESO
BIRAIL TROLLEY HOIST SUSPENDED

S2

Fig. 53

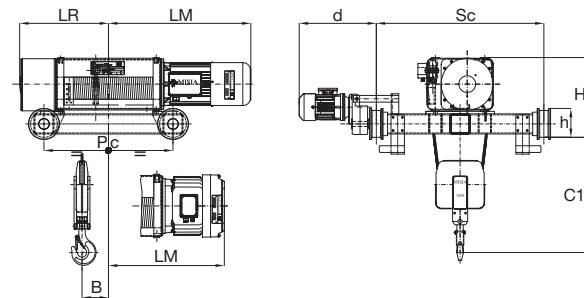

S2

Fig. 53C1

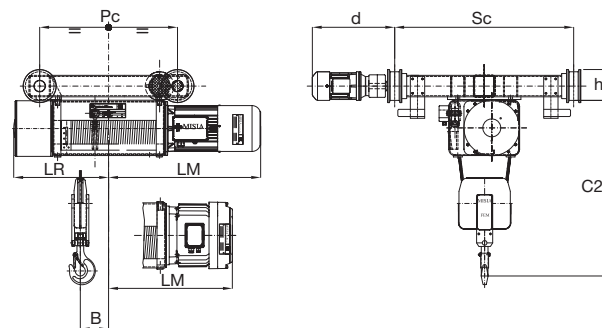

S2 - XM 308 / 312 / 316 / 525

Paranco Hoist	Portata Capacity	Corsa gancio Hook travel	Dimensioni Dimensions							Motori cilindrici Cylindrical motors				Motori conici Conical motors			Peso Weight			
			Sc mm	C1 mm	H mm	C2 mm	h mm	d mm	Pc mm	B mm	LR mm	Speed m/min	LM mm	Speed m/min	LM mm	Speed m/min		LM mm	Kg	
XM	t-max	m																		
308	1,6	10	1000	570	490	900	175	480	595	91	400	N	730	V	730	N	530	V	580	390
		720							154	460	790		790		640		400			
		900							244	550	880		880		730		430			
		1085							337	645	NA		975		VA		975		NA	775
312	2,5	10	1000	640	490	965	175	480	640	90	470	N	750	V	830	N	600	V	640	455
		770							155	535	815		895		705		475			
		975							258	640	920		1000		810		500			
		1175							358	740	NA		1020		VA		1100		NA	870
316	3,2	10	1000	640	490	965	175	480	640	90	470	N	770	V	830	N	640	/	/	480
		770							155	535	835		895		705		505			
		975							258	640	940		1000		810		535			
		1175							358	740	NA		1040		VA		1100		NA	910
525	5	10	1000	730	550	1110	175	510	655	90	500	N	840	V	900	N	650	V	740	580
		790							157	565	905		965		805		600			
		995							260	670	1010		1070		910		650			
		1195							360	770	NA		1110		VA		1170		NA	920

N - V - NA - VA = velocità di sollevamento (vedi pagine 18-19) / lifting speeds (see pages 18-19)



Paranchi standard SERIE XM XM SERIES standard hoists

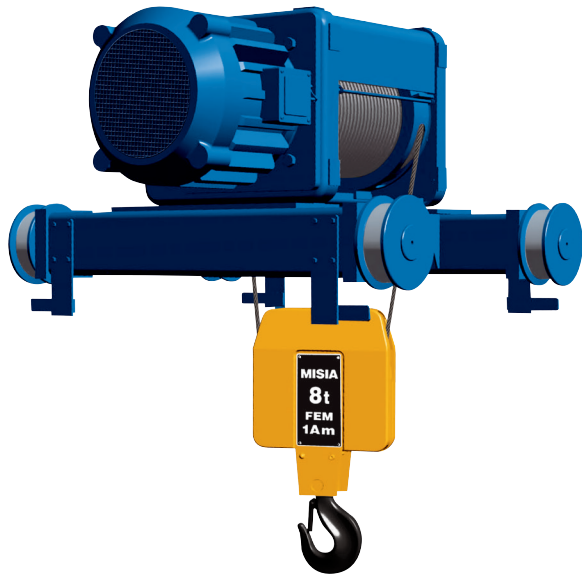

XM 740 / 750 / 950 / 963 / 980 / 1100 / 1125

S2 2 TIRI DI FUNE (2/1) - 2 ROPE FALLS (2/1)

Fig. 53 CARRELLO BIROTAIA CON PARANCO APPOGGIATO
BIRAIL TROLLEY HOIST SUPPORTED

Fig. 53C1 CARRELLO BIROTAIA CON PARANCO SOSPESO
BIRAIL TROLLEY HOIST SUSPENDED

S2

Fig. 53

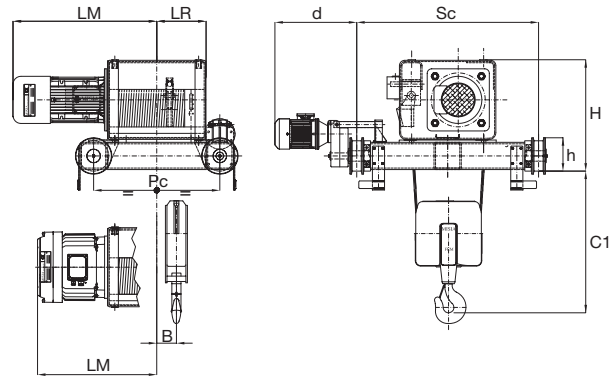

S2

Fig. 53C1

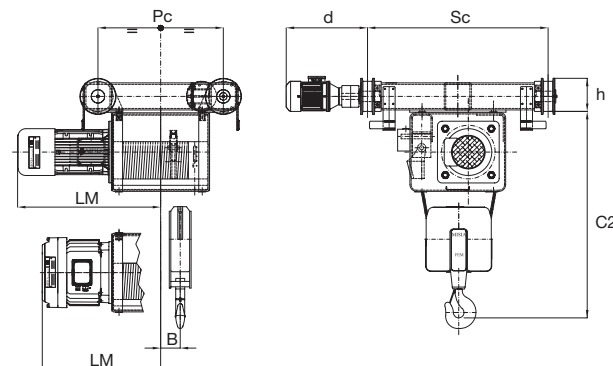

S2 - XM 740 / 750 / 950 / 963 / 980 / 1100 / 1125

Paranco Hoist	Portata Capacity	Corsa gancio Hook travel	Dimensioni Dimensions									Motori cilindrici Cylindrical motors				Motori conici Conical motors				Peso Weight			
			XM	t-max	m	Sc mm	C1 mm	H mm	C2 mm	h mm	d mm	Pc mm	B mm	LR mm	Speed m/min	LM mm	Speed m/min	LM mm	Speed m/min		LM mm	LM mm	Speed m/min
740	8	13	1200	840	740	1370	215	540	833	130	325	N	950	/	/	N	790	/	/	/	/	/	1080
		993							160	405	870		1130										
		1108							268	510	975		1190										
		1423							375	620	1080		1240										
		2075							688	940	1400		1400										
750	10	13	1200	860	740	1370	215	540	833	130	325	N	950	/	/	N	790	V	/	/	/	/	810
		993							160	405	870		1130										
		1108							268	510	975		1190										
		1423							375	620	1080		1240										
		2075							688	940	1400		1400										
950	10	20	1450	1100	880	1700	270	630	1160	230	480	N	1200	V	1240	N	940	V	/	/	/	/	1760
		1575							438	690	1150		1930										
		2075							688	940	1400		1400										
		2272							775	1080	1620		1620										
963	12,5	20	1450	1100	880	1700	270	630	1160	230	480	N	1200	V	1240	N	940	/	/	/	/	/	1940
		1575							438	690	1150		1930										
		2075							688	940	1400		1400										
		2272							775	1080	1620		1620										
980	16	20	1450	1100	880	1750	270	630	1160	230	480	N	1200	/	/	N	960	/	/	/	/	/	1770
		1575							438	690	1170		1950										
		2075							688	940	1420		2170										
		2272							775	1080	1620		1620										
1100*	20	20	1450	1330	1060	/	345	570	1337	305	610	/	/	/	/	N	1150	/	/	/	/	/	2350
		1522							400	705	1245						2430						
		1762							520	825	1365						2690						
		2272							775	1080	1620						1620						
1125*	25	20	1450	1330	1060	/	345	570	1337	305	610	/	/	/	/	N	1150	/	/	/	/	/	2350
		1522							400	705	1245						2430						
		1762							520	825	1365						2690						
		2272							775	1080	1620						1620						

* Solo in versione appoggiata / Only supported version

N - V - N A - V A = velocità di sollevamento (vedi pagine 18-19) / lifting speeds (see pages 18-19)



Paranchi standard SERIE XM XM SERIES standard hoists



XM 308 / 312 / 316 / 525

S4 4 TIRI DI FUNE (4/1) - 4 ROPE FALLS (2/1)

Fig. 53 CARRELLO BIROTAIA CON PARANCO APPOGGIATO
BIRAIL TROLLEY HOIST SUPPORTED

Fig. 53C1 CARRELLO BIROTAIA CON PARANCO SOSPESO
BIRAIL TROLLEY HOIST SUSPENDED

S4

Fig. 53

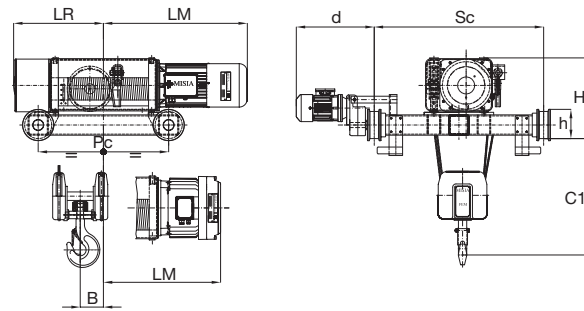

S4

Fig. 53C1

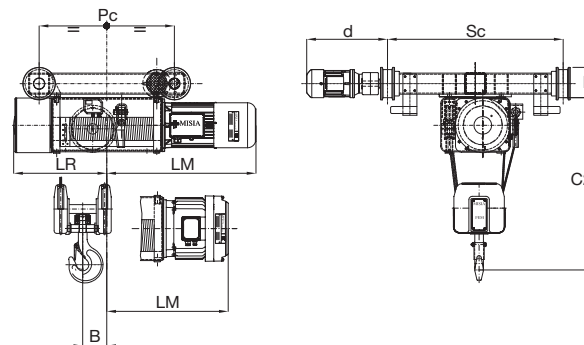

S4 - XM 308 / 312 / 316 / 525

Paranco Hoist	Portata Capacity	Corsa gancio Hook travel	Dimensioni Dimensions									Motori cilindrici Cylindrical motors				Motori conici Conical motors			Peso Weight	
			Sc mm	C1 mm	H mm	C2 mm	h mm	d mm	Pc mm	B mm	LR mm	Speed m/min	LM mm	Speed m/min	LM mm	Speed m/min	LM mm	LM mm		Kg
308	3,2	7	1000	520	490	845	175	480	720	132	460	N	790	V	790	N	590	V	640	420
		900							222	550	880		880		680		730		450	
		1085							314	645	NA		975		VA		975		NA	775
312	5	7	1000	590	490	920	175	480	770	137	535	N	815	V	895	N	665	V	745	495
		975							240	640	920		1000		770		810		530	
		1175							340	740	NA		1020		VA		1100		NA	870
316	6,3	7	1000	610	490	940	175	480	770	137	535	N	895	V	895	N	705	/	/	525
		975							240	640	1000		1000		810		/		560	
		1175							340	740	NA		1100		6/2		1100		NA	910
525	10	7	1000	650	550	1030	175	510	970	133	565	N	905	V	965	N	715	V	805	640
		995							236	670	1010		1070		820		910		690	
		1195							336	770	NA		1110		VA		1170		NA	920

N - V - N A - V A = velocità di sollevamento (vedi pagine 18-19) / lifting speeds (see pages 18-19)



Paranchi standard SERIE XM XM SERIES standard hoists

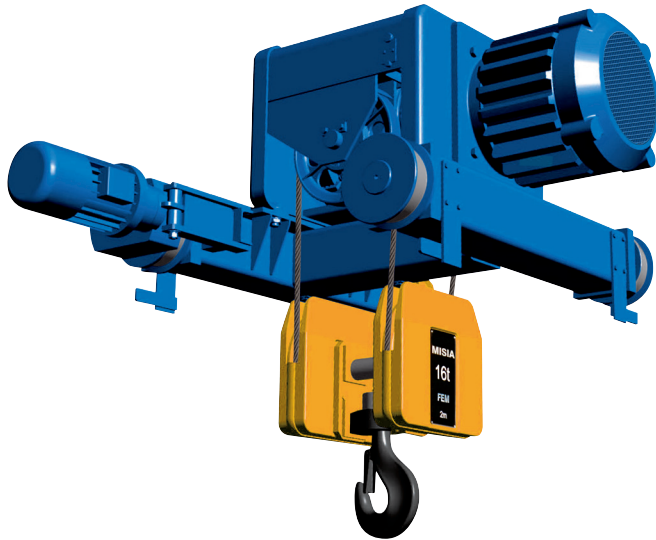

XM 740 / 750 / 950 / 963 / 980 / 1100 / 1125

S4 4 TIRI DI FUNE (4/1) - 4 ROPE FALLS (4/1)

Fig. 53 CARRELLO BIROTAIA CON PARANCO APPOGGIATO
BIRAIL TROLLEY HOIST SUPPORTED

Fig. 53C1 CARRELLO BIROTAIA CON PARANCO SOSPESO
BIRAIL TROLLEY HOIST SUSPENDED

S4

Fig. 53

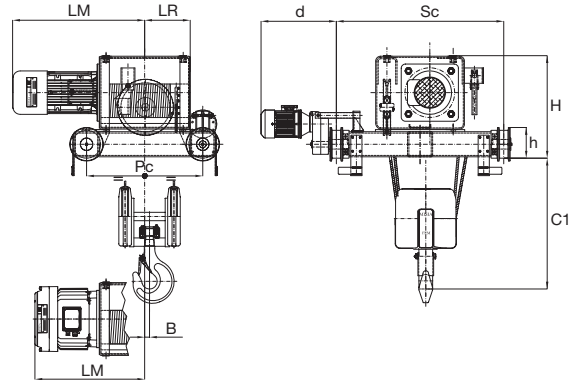

S4

Fig. 53C1

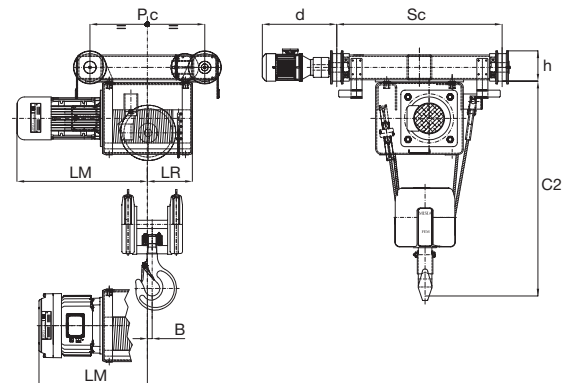

S4 - XM 740 / 750 / 950 / 963 / 980 / 1100 / 1125

Paranco Hoist	Portata Capacity	Corsa gancio Hook travel	Dimensioni Dimensions									Motori cilindrici Cylindrical motors				Motori conici Conical motors				Peso Weight
			Sc mm	C1 mm	H mm	C2 mm	h mm	d mm	Pc mm	B mm	LR mm	Speed m/min	LM mm	Speed m/min	LM mm	Speed m/min	LM mm	kg		
XM	t-max	m																		
740	16	6,5	1200	830	740	1360	215	540	833	35	325	N	950	/	/	N	790	/	/	650
		933							115	405	1030		870				690			
		1108							223	510	1135		975				740			
		1423							330	620	1245		1080				790			
		2075							588	940	1660		1400				1400			
750	20	6,5	1450	850	775	1380	270	570	873	35	325	N	950	/	/	N	790	V	/	810
		1033							115	405	1030		870				690			
		1248							223	510	1135		975				740			
		1463							330	620	1245		1080				790			
		2095							588	940	1660		1400				1400			
950	20	10	1450	1000	880	1630	270	570	1160	130	480	N	1200	V	1240	N	940	V	/	940
		1575							338	690	1460		1150				1220			
		2075							588	940	1660		1400				1400			
		2075							588	940	1660		1400				1400			
963	25	10	1450	1000	880	1630	270	570	1160	130	480	N	1200	/	/	N	940	/	/	1070
		1575							338	690	1460		1150				1220			
		2075							588	940	1660		1400				1400			
		2075							588	940	1660		1400				1400			
980	32	10	1450	1180	1100	1810	345	570	1180	130	480	N	1200	/	/	N	940	/	/	1090
		1585							338	690	1460		1150				1240			
		2095							588	940	1660		1400				1420			
		2095							588	940	1660		1400				1420			
1100*	40	10	2000	1270	1140		345	590	14347	193	610	/	/	/	/	N	1150	/	/	2700
		1622							285	705	1245						1365			3060
		1862							405	825	1365						1365			3060
		2372							660	1080	1620						1620			3700
1125*	50	10	2000	1270	1140		345	590	1437	193	610	/	/	/	/	N	1150	/	/	2700
		1622							285	705	1245						1365			2800
		1867							405	825	1365						1365			3060
		2372							660	1080	1620						1620			3700

* Solo in versione appoggiata / Only supported version

N - V - N A - V A = velocità di sollevamento (vedi pagine 18-19) / lifting speeds (see pages 18-19)



Modelo FEM N.º
A. Marca
B. Capacidad
C. Tipo de cable
D. Tipo de cable
E. Tipo de cable
F. Tipo de cable

MISIA
5,0t
FEM
2 m

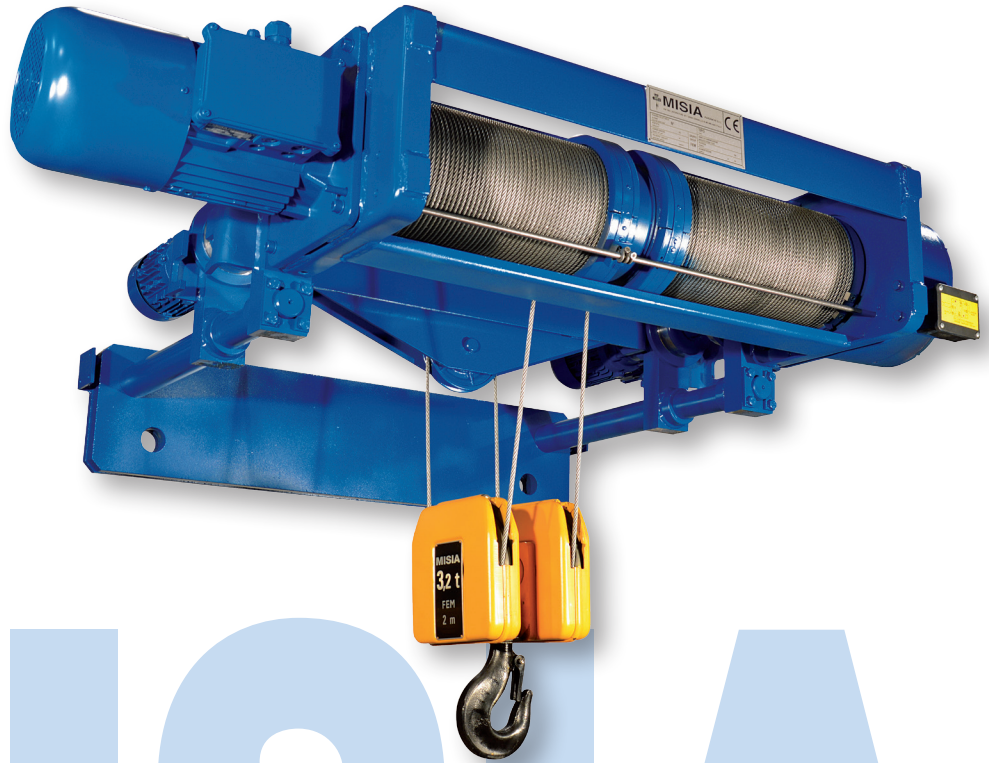
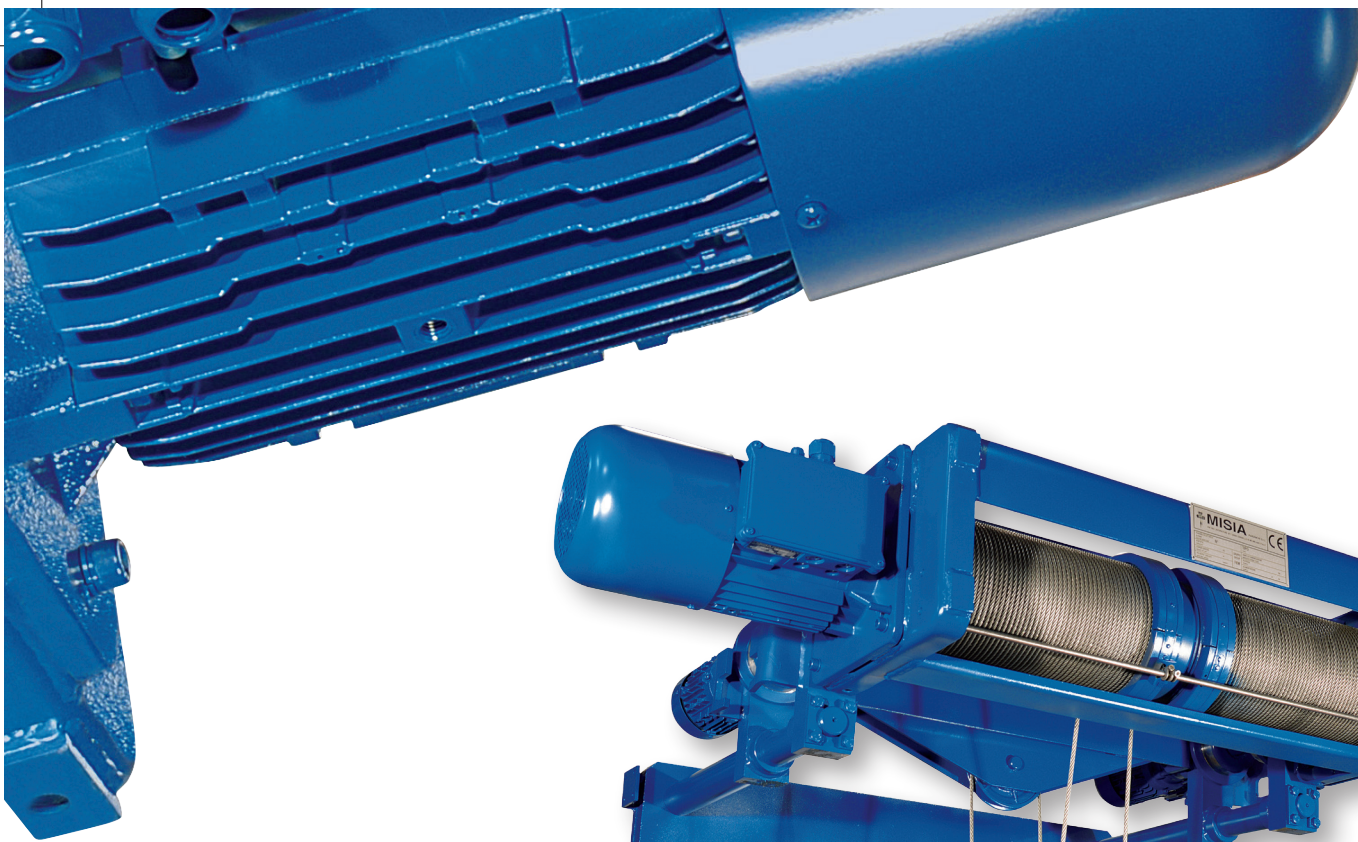

MISIA

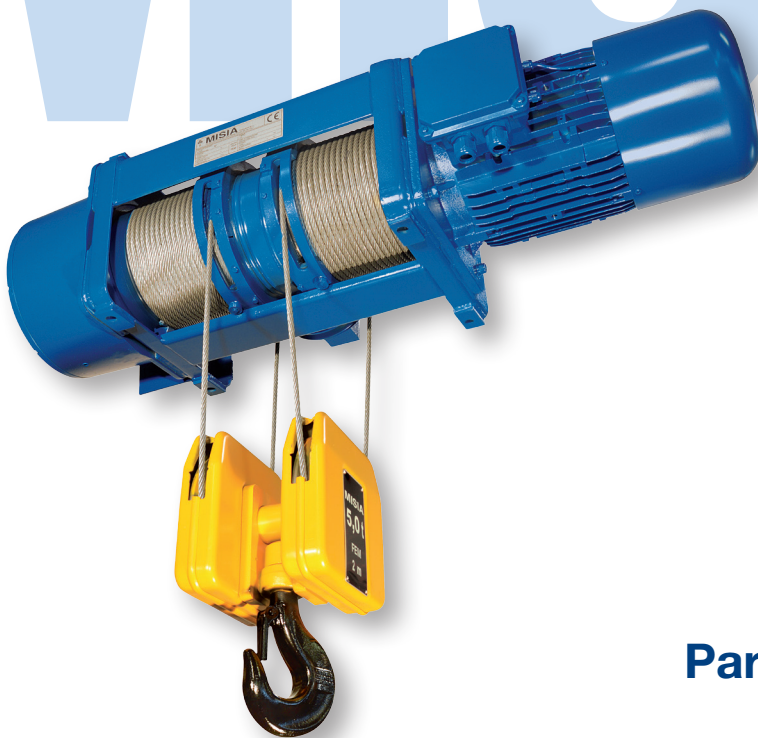

Paranchi a tiro centrale 4/2
True vertical lift 4/2



Paranchi standard SERIE XM
XM SERIES standard hoists

**PARANCHI A DOPPIA USCITA
DAL TAMBURO D2 (4/2) TIRO CENTRALE**
HOISTS WITH DOUBLE OUTLET
FROM THE DRUM D2 (4/2) TRUE VERTICAL LIFT



D2 - 4 TIRI DI FUNE (4/2) TIRO CENTRALE
D2 - 4 ROPE FALLS (4/2) TRUE VERTICAL LIFT

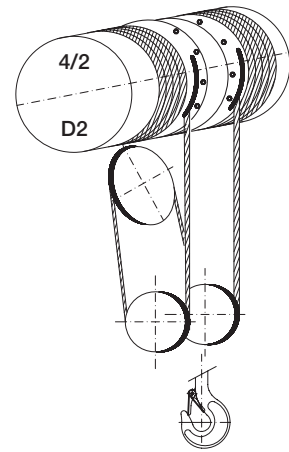

CARATTERISTICHE TECNICHE - TECHNICAL DATA

Portata max Max capacity	Gruppo Groupe	Paranco Hoist	Tiri fune Rope falls	Corse gancio Hook travel			Velocità sollevamento (m/min) Lifting speed (m/min)					
							1 velocità 1 speed		2 velocità 2 speed			
									Motori cilindrici Cylindrical motors		Motori conici Conical motors	
kg	FEM	XM		m	m	m	N	V	NA	VA	NA	VA
1600	2 m	308 D2	4/2	6	10	13	8	12	8/2,6	12/4	8/2,6	12/4
2500	2 m	312 D2	4/2	7,5	12	16	8	12	8/2,6	12/4	8/2,6	12/2
3200	2 m	316 D2	4/2	7,5	12	16	8	12	8/2,6	12/4	8/1,3	12/2
5000	2 m	525 D2	4/2	6	10	14	8	12	8/2,6	12/4	8/1,3	12/2
8000	1 Am	740 D2	4/2	7	11,5	16	8	12	8/2,6	/	8/1,3	/
10000	1 Am	750 D2	4/2	7	11,5	16	5	8	/	8/2,6	5/1,2	/
10000	2 m	950 D2	4/2	8	16	25	7,5	/	7,5/2,5	/	6/1,5	/
12500	1 Am	963 D2	4/2	8	16	25	7,5	/	7,5/2,5	/	5/1,2	/
16000	1 Am	980 D2	4/2	8	16	25	7,5	/	/	/	5/1,2	/

Le velocità sono riferite a una frequenza di 50 Hz / The lifting speed refer to a frequency of 50 Hz



Paranchi standard SERIE XM XM SERIES standard hoists

PARANCHI A DOPPIA USCITA DAL TAMBURO D2 (4/2) TIRO CENTRALE HOISTS WITH DOUBLE OUTLET FROM THE DRUM D2 (4/2) TRUE VERTICAL LIFT

Fig. 5 APPOGGIATO - SUPPORTED

Fig. 5C1 SOSPEO - SUSPENDED

XM 308 / 312 / 316 / 525

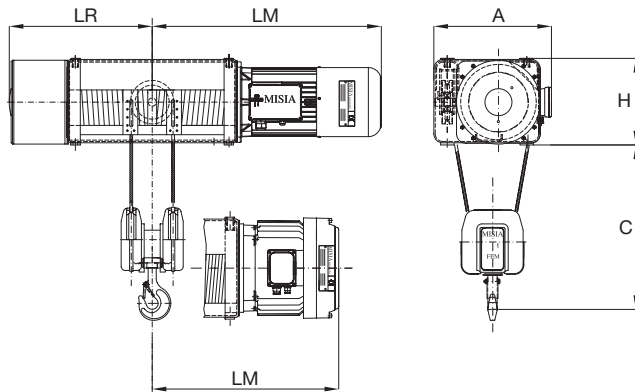

XM 740 / 750 / 950 / 963 / 980

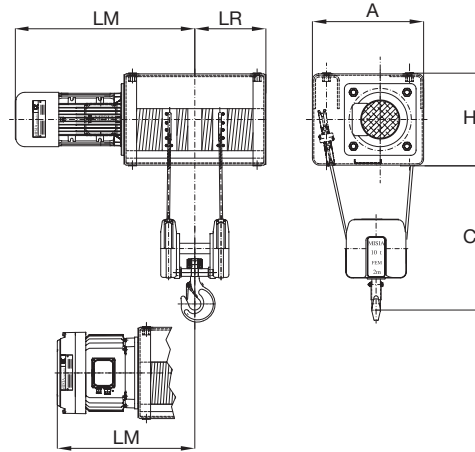

D2 (4/2) A 4 TIRI DI FUNE - D2 (4/2) 4 ROPE FALLS

Paranco Hoist	Portata Capacity	Corsa gancio Hook travel	Dimensioni Dimensions				Motori cilindrici Cylindrical motors				Motori conici Conical motors				Peso Weight
			C mm	H mm	A mm	LR mm	Speed m/min	LM mm	Speed m/min	LM mm	Speed m/min	LM mm	Speed m/min	LM mm	
308	1,6	6	500	325	460	460	N	790	V	790	N	645	V	702	170
		550				880		880		735		810		190	
		13				645	NA	975	VA	975	NA	830	VA	910	210
312	2,5	7,5	540	325	460	535	N	815	V	895	N	705	V	705	240
		640				920		1000		810		810		260	
		16				740	NA	1020	VA	1100	NA	910	VA	910	280
316	3,2	7,5	540	325	460	535	N	835	V	895	N	705	/	/	240
		640				940		1000		810		/		/	260
		16				740	NA	1040	VA	1100	NA	910	/	/	280
525	5	6	580	380	510	565	N	905	V	965	N	750	V	805	350
		670				1010		1070		860		910		390	
		14				770	NA	1110	VA	1170	NA	960	VA	1010	430
740	8	7	720	530	720	405	N	1030	/	/	N	870	/	/	640
		510				1135		/		/		975		/	/
		16				620	NA	1245	/	/	NA	1085	/	/	740
750	10	7	720	530	720	405	N	1030	/	/	N	870	V	890	640
		510				1135		/		/		975		/	995
		16				620	NA	1245	/	/	NA	1085	VA	1105	740
950	10	8	760	625	810	480	N	1100	/	/	N	940	/	/	1010
		690				1210		/		/		1150		/	/
		25				940	NA	1560	/	/	NA	1400	/	/	1340
963	12,5	8	760	625	810	480	N	1100	/	/	N	940	/	/	1010
		690				1210		/		/		1150		/	/
		25				940	NA	1560	/	/	NA	1400	/	/	1340
980	16	8	780	625	810	480	N	1180	/	/	N	960	/	/	1030
		690				1390		/		/		1170		/	/
		25				940	INVERTER	1640	/	/	NA	1420	/	/	1370

N - V - NA - VA = velocità di sollevamento (vedi pagine 38) / lifting speeds (see pages 38)



Paranchi standard SERIE XM XM SERIES standard hoists

PARANCHI A DOPPIA USCITA DAL TAMBURO D2 (4/2) TIRO CENTRALE HOISTS WITH DOUBLE OUTLET FROM THE DRUM D2 (4/2) TRUE VERTICAL LIFT

Fig. 3 A INGOMBRO NORMALE - NORMAL HEADROOM

XM 308 / 312 / 316 / 525

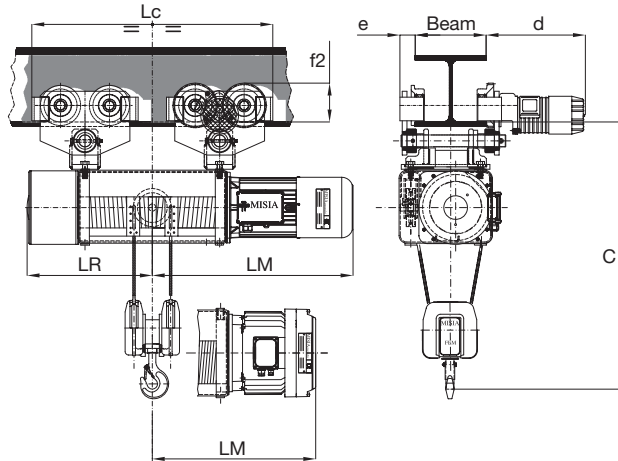

XM 740 / 750 / 950 / 963 / 980

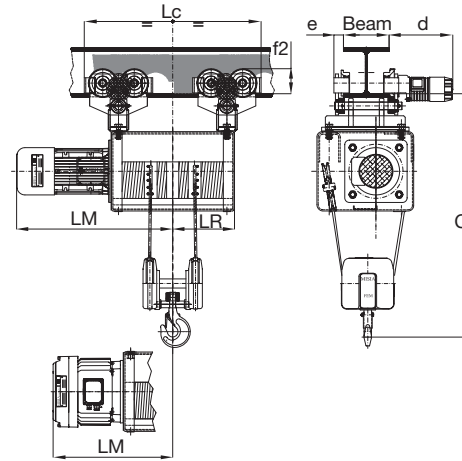

FIG. 3 CON CARRELLO MONOROTAIA D2 (4/2) A 4 TIRI DI FUNE - FIG. 3 MONORAIL TROLLEY D2 (4/2) 4 ROPE FALLS

Paranco Hoist	Portata Capacity	Corsa gancio Hook travel	Dimensioni Dimensions						Motori cilindrici Cylindrical motors				Motori conici Conical motors				Peso Weight
			XM	t-max	m	C mm	d mm	e mm	Lc mm	LR mm	f2 mm	Speed m/min	LM mm	Speed m/min	LM mm	Speed m/min	
308	1,6	6	1000	410	60	920	460	145	N	790	V	790	N	645	V	705	300
		1100				550	880		880	810	320						
		1285				645	NA		975	VA	975	NA	830	VA	910	335	
312	2,5	7,5	1040	410	60	970	535	145	N	815	V	895	N	705	V	705	370
		1175				640	920		1000	810	810	390					
		1375				740	NA		1020	VA	1100	NA	910	VA	910	415	
316	3,2	7,5	1040	410	60	970	535	145	N	835	V	895	N	705	/	/	400
		1175				640	940		1000	810	/	/	425				
		1375				740	NA		1040	VA	1100	NA	910	/	/	450	
525	5	6	1140	410	60	990	565	145	N	905	V	965	N	750	V	805	480
		1175				670	1010		1070	860	910	520					
		1395				770	NA		1110	VA	1170	NA	960	VA	1010	560	
740	8	7	1510	430	70	1165	405	165	N	1030	/	/	N	870	/	/	880
		1380				510	1135		/	/	975	/	/	930			
		1595				620	NA		1245	/	/	NA	1085	/	/	980	
750	10	7	1510	430	70	1165	405	165	N	1030	/	/	N	870	V	890	890
		1380				510	1135		/	/	975	/	/	995	930		
		1595				620	NA		1245	/	/	NA	1085	VA	1105	980	
950	10	8	1650	430	70	1290	480	165	N	1100	/	/	N	940	/	/	1270
		1705				690	1135		/	/	1150	/	/	1420			
		2205				940	NA		1245	/	/	NA	1400	/	/	1600	
963	12,5	8	1650	430	70	1290	480	165	N	1100	/	/	N	940	/	/	1270
		1705				690	1210		/	/	1150	/	/	1420			
		2205				940	NA		1560	/	/	NA	1400	/	/	1600	
980	16	8	1650	300	70	1290	480	165	N	1180	/	/	N	960	/	/	1270
		1705				690	1390		/	/	1170	/	/	1420			
		2205				940	NA		1640	/	/	NA	1420	/	/	1600	

Velocità carrello / Trolley speed: 18 - 18/6 m/min

N - V - NA - VA = velocità di sollevamento (vedi pagine 38) / lifting speeds (see pages 38)



Paranchi standard SERIE XM
XM SERIES standard hoists

**PARANCHI A DOPPIA USCITA
DAL TAMBURO D2 (4/2) TIRO CENTRALE**
HOISTS WITH DOUBLE OUTLET
FROM THE DRUM D2 (4/2) TRUE VERTICAL LIFT

Fig. 83 CARRELLO MONOTRAVE A INGOMBRO RIDOTTO
MONORAIL TROLLEY LOW HEADROOM

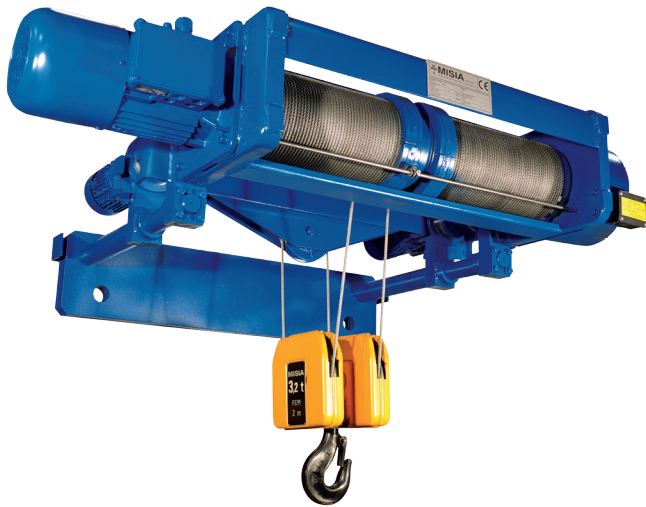

XM 308 / 312 / 316 / 525

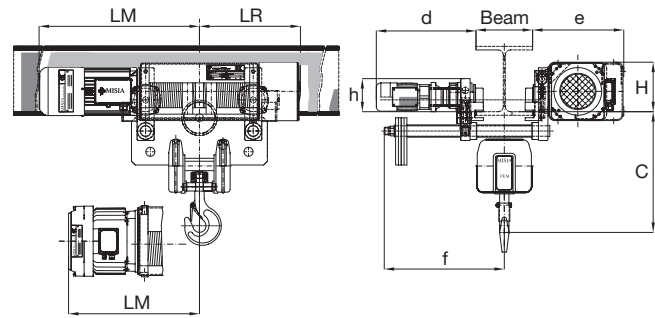

D2 (4/2) A 4 TIRI DI FUNE - D2 (4/2) 4 ROPE FALLS

Paranco Hoist	Portata Capacity	Corsa gancio Hook travel	Dimensioni Dimensions							Motori cilindrici Cylindrical motors				Motori conici Conical motors				Peso Weight
			C mm	H mm	h mm	d mm	e mm	f mm	LR mm	Speed m/min	LM mm	Speed m/min	LM mm	Speed m/min	LM mm	Speed m/min	LM mm	
308	1,6	6	660	240	140	430	470	410	460	N	790	V	790	N	645	V	702	360
		550							880		880		735		810		400	
		645							NA		975		VA		975		NA	830
312	2,5	7,5	600	240	140	430	470	410	535	N	815	V	895	N	705	V	705	490
		640							920		1000		810		810		540	
		740							NA		1020		VA		1100		NA	910
316	3,2	7,5	600	240	140	430	470	410	535	N	835	V	895	N	705	/	/	500
		640							940		1000		810		/		550	
		740							NA		1040		VA		1100		NA	910
525	5	6	680	305	140	485	550	440	565	N	905	V	965	N	750	V	805	660
		670							1010		1070		860		910		750	
		770							NA		1110		VA		1170		NA	960

N - V - N A - V A = velocità di sollevamento (vedi pagine 38) / lifting speeds (see pages 38)



Paranchi standard SERIE XM
XM SERIES standard hoists

XM 308 / 312 / 316 / 525

PARANCHI A DOPPIA USCITA
DAL TAMBURO D2 (4/2) TIRO CENTRALE
HOISTS WITH DOUBLE OUTLET
FROM THE DRUM D2 (4/2) TRUE VERTICAL LIFT

Fig. 53 CARRELLO BIROTAIA CON PARANCO APOGGIATO
BIRAIL TROLLEY HOIST SUPPORTED

Fig. 53C1 CARRELLO BIROTAIA CON PARANCO SOSPESO
BIRAIL TROLLEY HOIST SUSPENDED

XM 308 / 312 / 316 / 525

Fig. 53

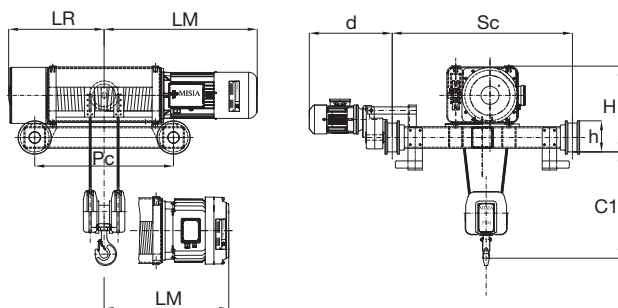

XM 308 / 312 / 316 / 525

Fig. 53C1

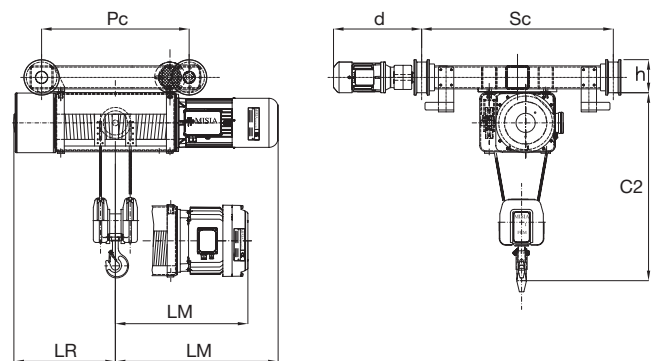

XM 308 / 312 / 316 / 525

Paranco Hoist	Portata Capacity	Corsa gancio Hook travel	Dimensioni Dimensions								Motori cilindrici Cylindrical motors				Motori conici Conical motors				Peso Weight
			Sc mm	C1 mm	H mm	C2 mm	h mm	d mm	Pc mm	LR mm	Speed m/min	LM mm	Speed m/min	LM mm	Speed m/min	LM mm	Speed m/min	LM mm	
308	1,6	6	1000	500	490	830	175	480	720	460	N	790	V	790	N	645	V	705	400
		900							550	880		880	735	810		430			
		1085							645	NA	975	VA	975	NA	830	VA	910	450	
312	2,5	7,5	1000	540	490	870	175	480	770	535	N	815	V	895	N	645	V	705	475
		975							640	920		1000	795	810		500			
		1175							740	NA	1020	VA	1100	NA	830	VA	910	530	
316	3,2	7,5	1000	540	490	870	175	480	770	535	N	835	V	895	N	705	/	/	505
		975							640	940		1000	810	/		535			
		1175							740	NA	1040	VA	1100	NA	910	/	565		
525	5	6	1000	580	550	960	175	510	790	565	N	905	V	965	N	750	V	805	600
		995							670	1010		1070	840	910		650			
		1195							770	NA	1110	VA	1170	NA	960	VA	1010	695	

Velocità carrello / Trolley speed: 20 - 16 - 20/6,5 - 16/5,3 m/min
N - V - NA - VA = velocità di sollevamento (vedi pagine 38) / lifting speeds (see pages 38)



Paranchi standard SERIE XM
XM SERIES standard hoists

XM 740 / 750 / 950 / 963 / 980

PARANCHI A DOPPIA USCITA
DAL TAMBURO D2 (4/2) TIRO CENTRALE
HOISTS WITH DOUBLE OUTLET
FROM THE DRUM D2 (4/2) TRUE VERTICAL LIFT

Fig. 53 CARRELLO BIROTAIA CON PARANCO APPOGGIATO
BIRAIL TROLLEY HOIST SUPPORTED

Fig. 53C1 CARRELLO BIROTAIA CON PARANCO SOSPESO
BIRAIL TROLLEY HOIST SUSPENDED

XM 740 / 750 / 950 / 963 / 980

Fig. 53

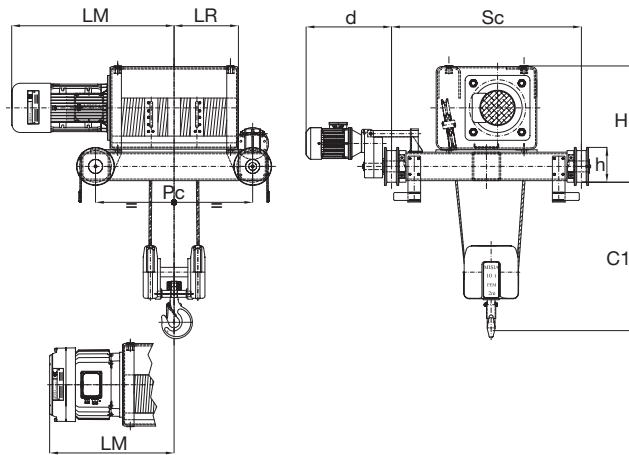

XM 740 / 750 / 950 / 963 / 980

Fig. 53C1

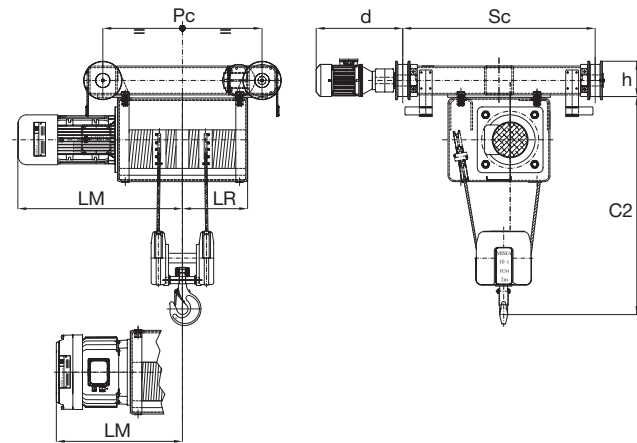

XM 740 / 750 / 950 / 963 / 980

Paranco Hoist	Portata Capacity	Corsa gancio Hook travel	Dimensioni Dimensions								Motori cilindrici Cylindrical motors				Motori conici Conical motors				Peso Weight		
			XM	t-max	m	Sc mm	C1 mm	H mm	C2 mm	h mm	d mm	Pc mm	LR mm	Speed m/min	LM mm	Speed m/min	LM mm	Speed m/min		LM mm	Speed m/min
740	8	7	1200	720	740	1260	215	540	993	405	N	1030	/	/	N	870	/	/	/	1130	
		1108							510	1135		975				1190					
		1423							620	1245		1080				1240					
750	10	7	1200	720	740	1260	215	540	993	405	N	1030	/	/	N	870	V	/	/	890	1130
		1108							510	1135		975				1190					
		1426							620	1245		1080				1105	1240				
950	10	8	1450	760	880	1400	270	630	1160	480	N	1200	V	1240	N	940	V	/	/	940	1750
		1575							690	1460		1500	1150	1930							
		2075							940	1660		1700	1400	2145							
963	12,5	8	1450	760	880	1400	270	630	1160	480	N	1200	/	/	N	940	/	/	/	1760	
		1575							690	1460		1150				1940					
		2075							940	1660		1400				2160					
980	16	8	1450	760	880	1400	270	630	1160	480	N	1200	/	/	N	960	/	/	/	1770	
		1575							690	1460		1170				1950					
		2075							940	1660		1420				2170					

Velocità carrello / Trolley speed: 20 - 16 - 20/6,5 - 16/5,3 m/min
N - V - N A - V A = velocità di sollevamento (vedi pagine 38) / lifting speeds (see pages 38)

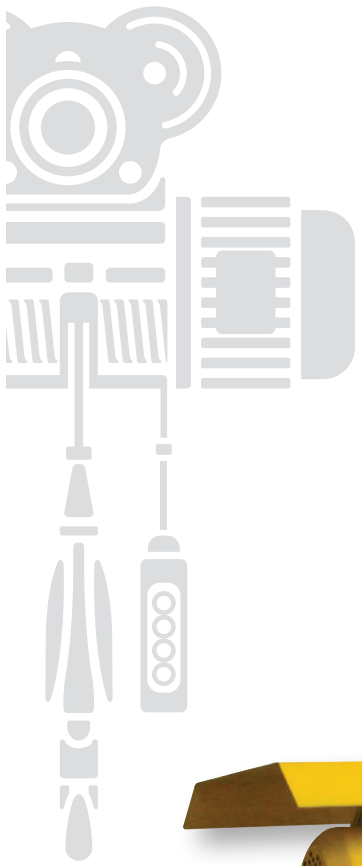

MISIA

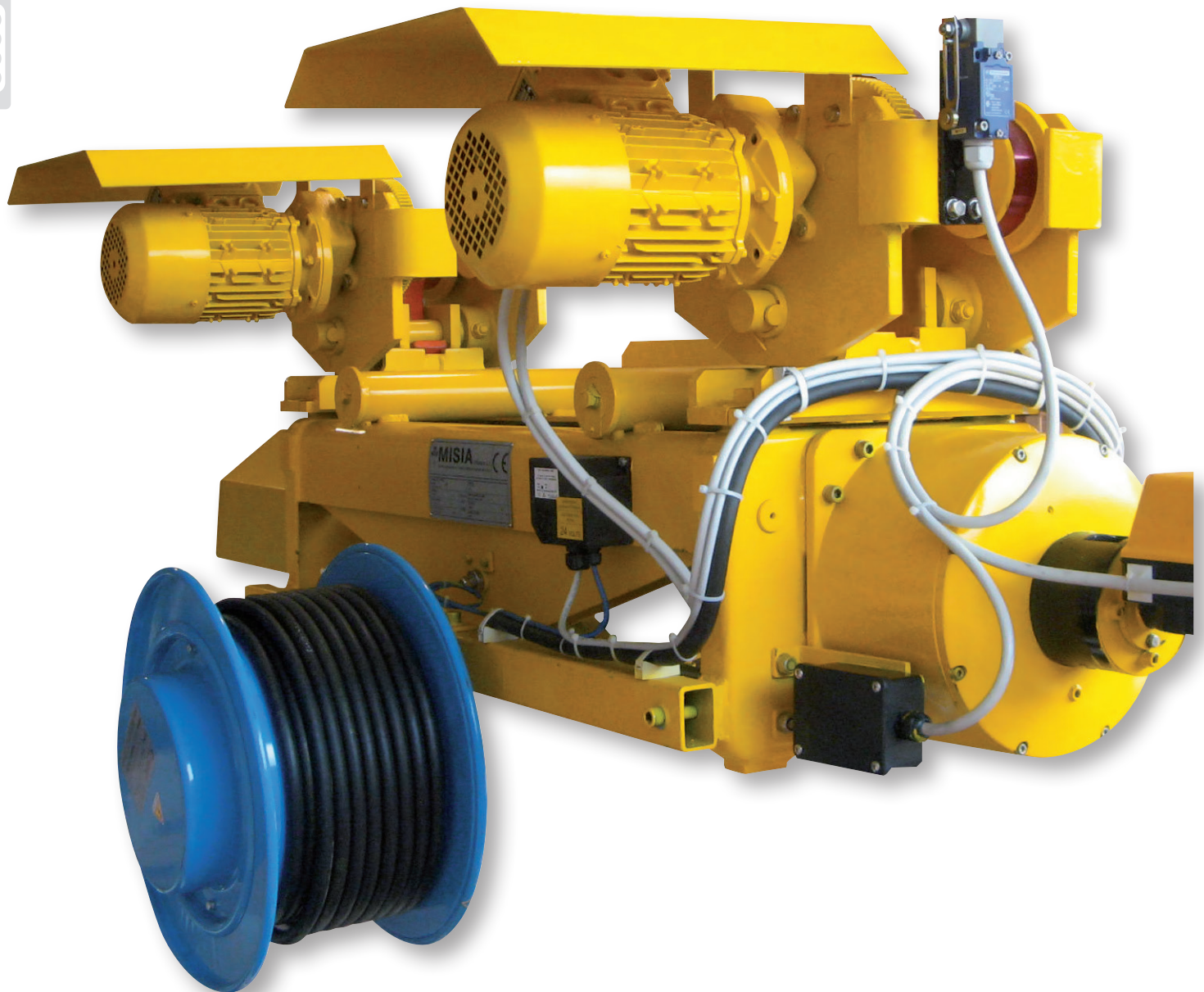

Paranchi speciali
Special hoists



Paranchi speciali SERIE XM XM SERIES special hoists

TIPO DC2 A DOPPIA USCITA DI FUNE E SINGOLO TIRO CONTRAPPOSTO RINVIATO Paranchi a doppia uscita dal tamburo

TYPE DC2 OPPOSITE DOUBLE ROPE OUTPUT
WITH 2/2+2 ROPE FALLS
Hoists with double outlet from the drum

XM 308 / 312 / 316 / 525

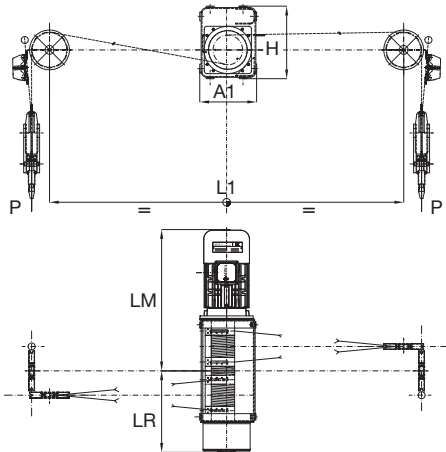

XM 740 / 750 / 950 / 963 / 980

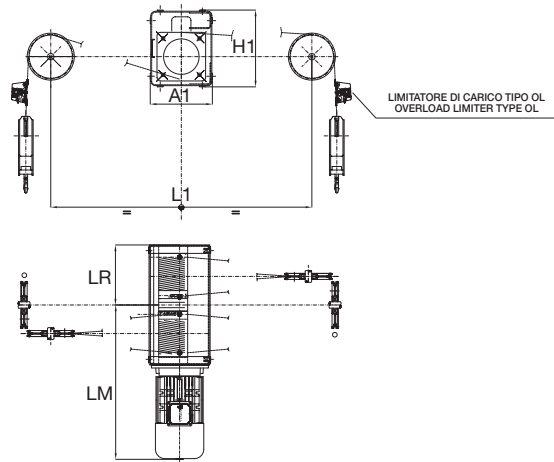

CARATTERISTICHE TECNICHE - TECHNICAL DATA

Portata max Max capacity	Gruppo Groupe	Paranco Hoist	Tiri fune Rope falls	Corse gancio Hook travel		Velocità sollevamento (m/min) Lifting speed (m/min)						
						1 velocità 1 speed		2 velocità 2 speed				
								Motori cilindrici Cylindrical motors		Motori conici Conical motors		
kg	FEM	XM		m	m	m	N m/min	V m/min	NA m/min	VA m/min	NA m/min	VA m/min
800+800	2 m	308 DC2	2 + 2/2	6	10	13	8	12	8/2,6	12/4	8/2,6	12/4
1250+1250	2 m	312 DC2	2 + 2/2	7,5	12	16	8	12	8/2,6	12/4	8/2,6	12/4
1600+1600	2 m	316 DC2	2 + 2/2	7,5	12	16	8	12	8/2,6	12/4	8/1,3	12/2
2500+2500	2 m	525 DC2	2 + 2/2	6	10	14	8	12	8/2,6	12/4	8/1,3	12/2
4000+4000	1 Am	740 DC2	2 + 2/2	7	11,5	16	8	12	8/2,6	/	8/1,3	/
5000+5000	1 Am	750 DC2	2 + 2/2	7	11,5	16	5	8	/	8/2,6	5/1,2	8/1,3
5000+5000	2 m	950 DC2	2 + 2/2	11	21	32,5	7,5	/	7,5/2,5	/	6/1,5	/
6300+6300	1 Am	963 DC2	2 + 2/2	11	21	32,5	7,5	/	7,5/2,5	/	5/1,2	/
8000+8000	1 Am	980 DC2	2 + 2/2	8,5	16,5	26	7,5	/	/	/	5/1,2	/

Le velocità sono riferite a una frequenza di 50 Hz / The lifting speed refer to a frequency of 50 Hz

DC2 (2/2+2) A 2+2 TIRI DI FUNE - DC2 (2/2+2) 2+2 ROPE FALLS

Paranco/Hoist		XM	308	312	316	525	740	750	950	963	980
Tipo/Type		DC2 (2/2+2)									
Capacità/Capacity (P)		t	0,8+0,8	1,25+1,25	1,6+1,6	2,5+2,5	4+4	5+5	5+5	6,3+6,3	8+8
Corsa gancio/Hook travel		m	6 10 13	7,5 12 16	7,5 12 16	6 10 14	7 11,5 16	7 11,5 16	11 21 32	11 21 32	8,5 16,5 26
H1		mm	400	400	400	450	640	640	730	730	730
A1		mm	310	310	310	360	545	545	600	600	600
min. L1		mm	2390 3680 4990	2520 3980 5405	2520 3980 5405	2460 3920 5350	2660 4200 5740	2660 4200 5740	3430 6400 9980	3430 6400 9980	3330 6290 9870
LR		mm	460 550 645	535 640 740	535 640 740	565 670 770	405 510 620	405 510 620	480 690 940	480 690 940	480 690 940
Motori cilindrici Cylindrical motor	Vel. soll./Lift. speed	m/min	N - N A	N - N A	N - N A	N - N A	N - N A	N - N A	N - N A	N - N A	N - N A
	LM	mm	790 880 975	815 920 1020	895 940 1040	905 1010 1110	1030 1135 1245	1030 1135 1245	1100 1210 1560	1100 1210 1560	1180 1390 1640
	Vel. soll./Lift. speed	m/min	V - V A	V - V A	V - V A	V - V A	/	/	/	/	/
Motori conici Conical motor	LM	mm	790 880 975	895 1000 1100	895 1000 1100	965 1070 1170	/	/	/	/	/
	Vel. soll./Lift. speed	m/min	N - N A	N - N A	N - N A	N - N A	N - N A	N - N A	N - N A	N - N A	N - N A
	LM	mm	645 735 830	705 810 910	705 810 910	715 820 920	870 975 1085	870 975 1085	940 1150 1400	940 1150 1400	960 1170 1420
Vel. soll./Lift. speed	m/min	V - V A	V - V A	/	V - V A	/	V - V A	/	/	/	
LM	mm	640 730 825	705 810 910	/	805 910 1010	/	890 995 1105	/	/	/	
Peso/Weight		kg	150 170 190	220 240 260	220 240 260	330 370 410	620 670 720	620 670 720	980 1130 1300	980 1130 1300	980 1130 1300

N - V - N A - V A = velocità di sollevamento (vedi tabella sopra) / lifting speeds (see table above)



Paranchi speciali SERIE XM XM SERIES special hoists

TIPO DC1 A DOPPIA USCITA E SINGOLO TIRO CONTRAPPOSTO Paranchi a doppia uscita dal tamburo

TYPE DC1 OPPOSITE DOUBLE ROPE
OUTPUT WITH 2/1+1 ROPE FALLS
Hoists with double outlet from the drum

XM 308 / 312 / 316 / 525

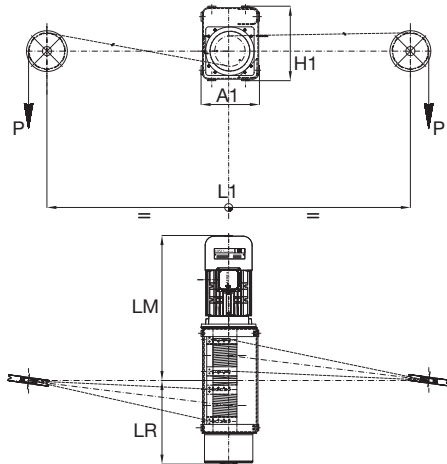

XM 740 / 750 / 950 / 963 / 980

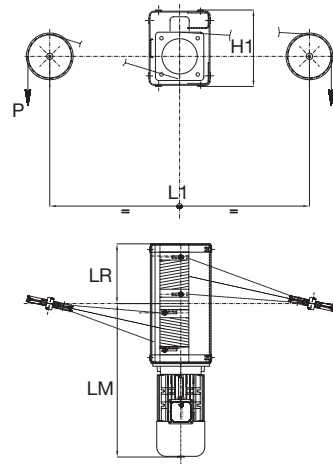

CARATTERISTICHE TECNICHE - TECHNICAL DATA

Portata max Max capacity	Gruppo Groupe	Paranco Hoist	Tiri fune Rope falls	Corse gancio Hook travel			Velocità sollevamento (m/min) Lifting speed (m/min)					
							1 velocità 1 speed		2 velocità 2 speed			
							N m/min	V m/min	Motori cilindrici Cylindrical motors		Motori conici Conical motors	
kg	FEM	XM	m			N m/min	V m/min	NA m/min	VA m/min	NA m/min	VA m/min	
400+400	2 m	308 DC1	1 + 1/2	12	20	26	16	24	16/5,2	24/8	16/5,2	24/8
625+625	2 m	312 DC1	1 + 1/2	15	24	32	16	24	16/5,2	24/8	16/5,2	24/8
800+800	2 m	316 DC1	1 + 1/2	15	24	32	16	24	16/5,2	24/8	16/2,6	/
1250+1250	2 m	525 DC1	1 + 1/2	12	20	28	16	24	16/5,2	24/8	16/2,6	24/4
2000+2000	1 Am	740 DC1	1 + 1/2	14	23	32	16	24	16/5,2	/	16/2,6	/
2500+2500	1 Am	750 DC1	1 + 1/2	14	23	32	10	16	/	16/5,2	10/2,5	/
2500+2500	2 m	950 DC1	1 + 1/2	22	42	65	15	/	15/5	/	12/3	/
3150+3150	1 Am	963 DC1	1 + 1/2	22	42	65	15	/	15/5	/	10/2,5	/
4000+4000	1 Am	980 DC1	1 + 1/2	17	33	52	15	/	/	/	10/2,5	/

Le velocità sono riferite a una frequenza di 50 Hz / The lifting speed refer to a frequency of 50 Hz

DC1 (2/1+1) A 1+1 TIRI DI FUNE - DC1 (2/1+1) 1+1 ROPE FALLS

Paranco/Hoist		XM	308	312	316	525	740	750	950	963	980	
Tipo/Type		DC1 (2/1+1)										
Capacità/Capacity (P)		t	0,4+0,4	0,625+0,625	0,8+0,8	1,25+1,25	2+2	2,5+2,5	2,5+2,5	3,15+3,15	4+4	
Corsa gancio/Hook travel		m	12 20 26	15 24 32	15 24 32	12 20 28	14 23 32	14 23 32	/ / /	/ / /	/ / /	
H1		mm	400	400	400	450	640	640	730	730	730	
A1		mm	310	310	310	360	545	545	600	600	600	
min. L2		mm	2400 3700 5000	2550 4000 5450	2550 4000 5450	2500 3950 5400	2700 4250 5800	2700 4250 5800	3450 6450 10000	3450 6450 10000	3400 6300 9900	
LR		mm	460 550 645	535 640 740	535 640 740	565 670 770	405 510 620	405 510 620	480 690 940	480 690 940	480 690 940	
Motori cilindrici Cylindrical motor	Vel. soll./Lift. speed	m/min	N - NA	N - NA	N - NA	N - NA	N - NA	N - NA	N - NA	N - NA	N - NA	
	LM	mm	790 880 975	815 920 1020	835 940 1040	905 1010 1110	1030 1135 1245	1030 1135 1245	1100 1210 1560	1100 1210 1560	1180 1390 1640	
	Vel. soll./Lift. speed	m/min	V - VA	V - VA	V - VA	V - VA	/	/	/	/	/	
Motori conici Conical motor	Vel. soll./Lift. speed	m/min	N - NA	N - NA	N - NA	N - NA	N - NA	N - NA	N - NA	N - NA	N - NA	
	LM	mm	590 680 775	665 770 870	705 810 910	715 820 920	870 975 1085	870 975 1085	940 1150 1400	940 1150 1400	960 1170 1420	
	Vel. soll./Lift. speed	m/min	V - VA	V - VA	/	V - VA	/	/	V - VA	/	/	
Peso/Weight		kg	150 170 190	220 240 260	220 240 260	330 370 410	620 670 720	620 670 720	980 1130 1300	980 1130 1300	980 1130 1300	

N - V - NA - VA = velocità di sollevamento (vedi tabella sopra) / lifting speeds (see table above)



Paranchi speciali SERIE XML XML SERIES special hoists

PARANCI SPECIALI S2 - A 2 TIRI DI FUNE (2/1) CORSE GANCIO LUNGHE SPECIAL HOIST S2 - 2 ROPE FALLS (2/1) HIGH LIFTING HEIGHT

Fig. 5 APPOGGIATO - SUPPORTED

Fig. 5C1 SOSPEO - SUSPENDED



Fig. 5 / Fig. 5C1

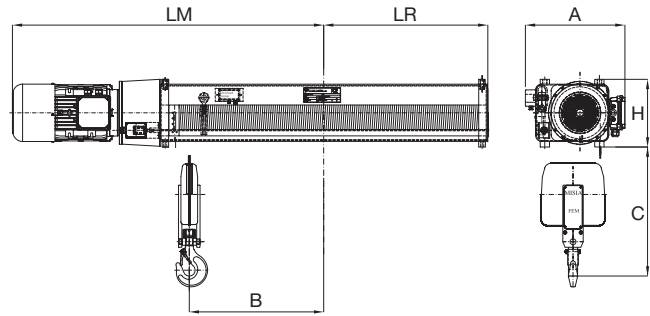

CARATTERISTICHE TECNICHE PARANCI SERIE XML - TECHNICAL DATA HOISTS XML SERIES

Portata max Max capacity	Gruppo Groupe	Paranco Hoist	Tiri fune Rope falls	Corse gancio Hook travel				Velocità sollevamento - Potenza motore Lifting speed - Motor power							
								N		NA		V		VA	
								m/min	kW	m/min	kW	m/min	kW	m/min	kW
1600	2 m	308	2/1	46	57	68	79	8	2,5	8/2,6	2,5/0,8	12	4	12/4	4/1,3
2500	2 m	312	2/1	32	40	48	56	8	4	8/2,6	4/1,3	12	6	12/4	6/2
3200	2 m	316	2/1	32	40	48	56	8	5	8/2,6	5/1,6	12	7	12/4	7/2,3
5000	2 m	525	2/1	32	40	48	56	8	8	8/2,6	8/2,6	12	12	12/4	12/4

5 - APPOGGIATO / 5C1 - SOSPEO - 5 - SUPPORTED / 5C1 - SUSPENDED

Paranco Hoist	Portata Capacity	Corsa gancio Hook travel	Dimensioni Dimensions					Motori cilindrici Cylindrical motors				Peso Weight
			C mm	H mm	A mm	LR mm	B mm	Speed m/min	LM mm	Speed m/min	LM mm	
308	1,6	46	570	370	450	625	459	N	1260	V	1260	320
						760	594		1400		1400	340
						890	727		1530		1530	360
						1025	862		NA		1660	VA
312	2,5	32	640	370	450	625	459	N	1260	V	1260	1330
						760	594		1400		1470	350
						890	727		1530		1600	370
						1025	862		NA		1660	VA
316	3,2	40	640	370	450	625	459	N	1300	V	1300	1330
						760	594		1440		1470	350
						890	727		1570		1600	370
						1025	862		NA		1700	VA
525	5	32	730	440	510	640	445	N	1400	V	1400	1450
						775	580		1530		1580	440
						910	715		1665		1715	470
						1045	850		NA		1800	VA

N - V - NA - VA = velocità di sollevamento (vedi tabella sopra) / lifting speeds (see table above)



Paranchi speciali SERIE XML XML SERIES special hoists

PARANCHI SPECIALI S2 - A 2 TIRI DI FUNE (2/1) CORSE GANCIO LUNGHE SPECIAL HOIST S2 - 2 ROPE FALLS (2/1) HIGH LIFTING HEIGHT

Fig. 3 CARRELLO MONOTRAVE A INGOMBRO NORMALE
NORMAL HEADROOM TROLLEY

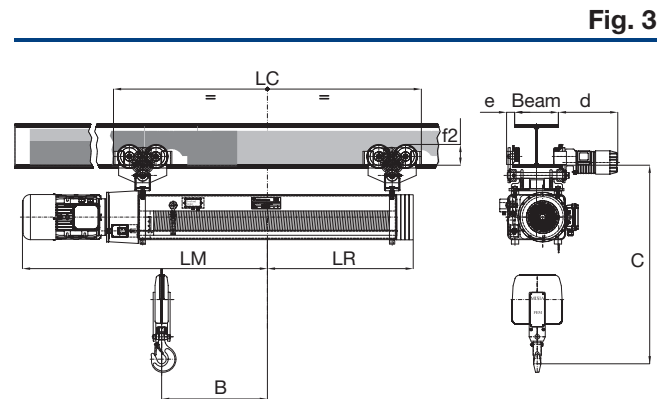

Fig. 3

CARATTERISTICHE TECNICHE PARANCHI SERIE XML - TECHNICAL DATA HOISTS XML SERIES

Portata max Max capacity	Gruppo Groupe	Paranco Hoist	Tiri fune Rope falls	Corse gancio Hook travel				Velocità sollevamento - Potenza motore Lifting speed - Motor power							
				m	m	m	m	N		NA		V		VA	
								m/min	kW	m/min	kW	m/min	kW	m/min	kW
1600	2 m	308	2/1	46	57	68	79	8	2,5	8/2,6	2,5/0,8	12	4	12/4	4/1,3
2500	2 m	312	2/1	32	40	48	56	8	4	8/2,6	4/1,3	12	6	12/4	6/2
3200	2 m	316	2/1	32	40	48	56	8	5	8/2,6	5/1,7	12	7	12/4	7/2,3
5000	2 m	525	2/1	32	40	48	56	8	8	8/2,6	8/2,6	12	12	12/4	12/4

3 - CARRELLO A INGOMBRO NORMALE - 3 - NORMAL HEADROOM TROLLEY

Paranco Hoist	Portata Capacity	Corsa gancio Hook travel	Dimensioni Dimensions							Motori cilindrici Cylindrical motors				Peso Weight
			c mm	d mm	e mm	LC mm	LR mm	B mm	f2 mm	Speed m/min	LM mm	Speed m/min	LM mm	
308	1,6	46	1070	410	55	1580	800	459	145	N	1260	V	1260	520
						1850	940	594			1400		1400	
						2115	1070	727			1530		1530	
						2385	1200	862			1660		VA	
312	2,5	32	1140	410	55	1580	800	459	145	N	1260	V	1330	530
						1850	940	594			1400		1470	
						2115	1070	727			1530		1600	
						2385	1200	862			1660		VA	
316	3,2	40	1140	410	55	1580	800	459	145	N	1300	V	1330	530
						1850	940	594			1440		1470	
						2115	1070	727			1570		1600	
						2385	1200	862			1700		VA	
525	5	32	1270	430	70	1660	825	445	165	N	1400	V	1450	670
						1930	960	580			1530		1580	
						2200	1100	715			1665		1715	
						2470	1230	850			1800		VA	

Velocità carrello / Trolley speed: 18 - 18/6 m/min

N - V - NA - VA = velocità di sollevamento (vedi tabella sopra) / lifting speeds (see table above)



Paranchi speciali SERIE XML XML SERIES special hoists

PARANCHI SPECIALI S2 - A 2 TIRI DI FUNE (2/1) CORSE GANCIO LUNGHE SPECIAL HOIST S2 - 2 ROPE FALLS (2/1) HIGH LIFTING HEIGHT

Fig. 53 CARRELLO BIROTAIA CON PARANCO APOGGIATO
BIRAIL TROLLEY HOIST SUPPORTED

Fig. 53C1 CARRELLO BIROTAIA CON PARANCO SOSPESO
BIRAIL TROLLEY HOIST SUSPENDED

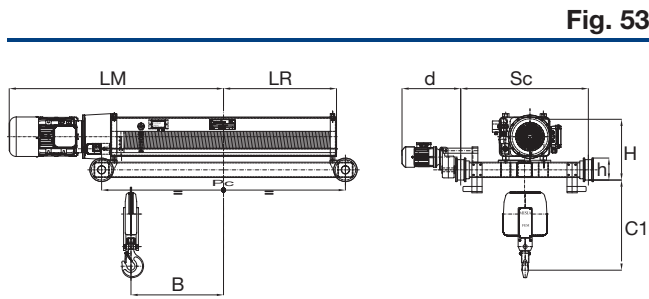

Fig. 53

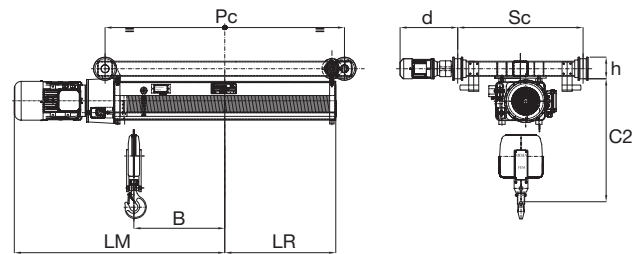

Fig. 53C1

CARATTERISTICHE TECNICHE PARANCHI SERIE XML - TECHNICAL DATA HOISTS XML SERIES

Portata max Max capacity	Gruppo Groupe	Paranco Hoist	Tiri fune Rope falls	Corse gancio Hook travel				Velocità sollevamento - Potenza motore Lifting speed - Motor power							
				m	m	m	m	N		NA		V		VA	
								m/min	kW	m/min	kW	m/min	kW	m/min	kW
1600	2 m	308	2/1	46	57	68	79	8	2,5	8/2,6	2,5/0,8	12	4	12/4	4/1,3
2500	2 m	312	2/1	32	40	48	56	8	4	8/2,6	4/1,3	12	6	12/4	6/2
3200	2 m	316	2/1	32	40	48	56	8	5	8/2,6	5/1,7	12	7	12/4	7/2,3
5000	2 m	525	2/1	32	40	48	56	8	8	8/2,6	8/2,6	12	12	12/4	12/4

53-53C1 - CARRELLO BIROTAIA - 53-53C1 - BIRAIL TROLLEY

Paranco Hoist	Portata Capacity	Corsa gancio Hook travel	Dimensioni Dimensions											Motori cilindrici Cylindrical motors				Peso Weight	
			Sc mm	C1 mm	H mm	C2 mm	h mm	d mm	Pc mm	B mm	Lr mm	f2 mm	Speed m/min	LM mm	Speed m/min	LM mm	Kg		
308	1,6	46	1000	570	490	900	175	480	1375	459	625	145	N	1260	V	1260	550		
		57							1645	594	760							1400	1400
		68							1910	727	890							1530	1530
		79							2180	862	1025							1660	1660
312	2,5	32	1000	640	490	965	175	480	1375	459	625	145	N	1260	V	1330	560		
		40							1645	594	760							1400	1400
		48							1910	727	890							1530	1530
		56							2180	862	1025							1660	1660
316	3,2	32	1000	640	490	965	175	480	1375	459	625	145	N	1300	V	1330	590		
		40							1645	594	760							1440	1440
		48							1910	727	890							1570	1570
		56							2180	862	1025							1700	1700
525	5	32	1000	730	550	1110	175	480	1400	445	640	165	N	1400	V	1450	650		
		40							1670	580	775							1530	1530
		48							1940	715	910							1665	1665
		56							2210	850	1045							1800	1800

N - V - NA - VA = velocità di sollevamento (vedi tabella sopra) / lifting speeds (see table above)



Paranchi speciali 6/1 6/1 special hoists

PARANCHI SPECIALI A SINGOLA USCITA FUNE DAL TAMBURO 6/1

SPECIAL HOIST WITH SINGLE OUTLET
FROM THE DRUM 6/1

SR6 A 6 TIRI DI FUNE (6/1) - 6 ROPE FALLS (6/1)

Fig. 5 PARANCO APPOGGIATO - SUPPORTED HOIST

**Fig. 53 CARRELLO PARANCO MONOROTAIA
HOIST TROLLEY BIRAIL**

SR6

Fig. 5

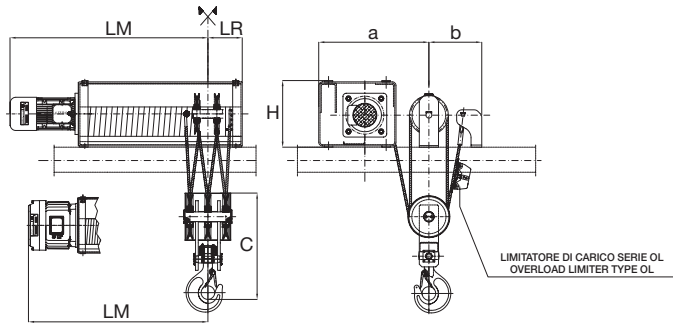

SR6

Fig. 53

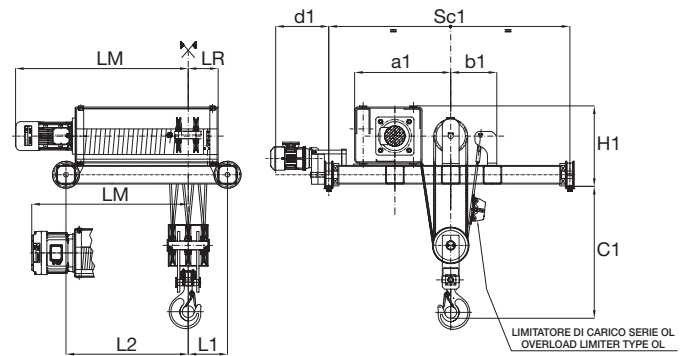

SR6 - A 6 TIRI DI FUNE (6/1) - SR6 - 6 ROPE FALLS (6/1)

Paranco/Hoist		XM	740			750			950			963			980		
Portata/Capacity		kg	24000			30000			30000			37500			48000		
Gruppo/Groupe		FEM	1Am			1Am			2m			1Am			1Am		
Corsa gancio/Hook travel		m	6,5	11	15	6,5	11	15	6,5	10,5	16	6,5	10,5	16	6,5	10,5	16
Motori cilindrici Cylindrical motor	Vel. soll./Lift. speed	m/min	2,7			2,7			2,5			3			2,5		
	Pot. mot./Mot. power	kW	12			15			15			24			24		
	Vel. soll./Lift. speed	m/min	2,7/0,9			2,7/0,9			2,5/0,8			2,5/0,8			-		
	Pot. mot./Mot. power	kW	12/4			15/5			16/5,3			22/7,3			-		
Motori conici Conical motor	Vel. soll./Lift. speed	m/min	2,7			2,7			2			1,7			1,7		
	Pot. mot./Mot. power	kW	12,5			15			12,5			12,5			16		
	Vel. soll./Lift. speed	m/min	2,7/0,3			2,7/0,5			2/0,5			1,7/0,4			1,7/0,4		
	Pot. mot./Mot. power	kW	13/3			15/2,5			13/3			13/3			16/4		
Fig 5	H	mm	530			530			625			625			625		
	c	mm	900			1000			1100			1100			1240		
	a	mm	840			840			990			990			990		
	b	mm	380			380			480			480			480		
	LR	mm	250			257			277			288			189		
Motori cilindrici/Cylindrical motor	LM	mm	1175	1605	1995	1165	1595	1985	1305	1720	2220	1370	1790	2290	/	/	/
Motori conici/Conical motor	LM	mm	1065	1495	1885	1065	1495	1885	1125	1540	2040	1190	1610	2110	1290	1710	2210
Peso/Weight	≈	kg	900	1000	1080	980	1080	1160	1480	1630	1810	1480	1630	1810	1610	1760	1940
Fig 53	SC1	mm	2000			2000			2500			2500			2500		
	H1	mm	790			790			900			900			940		
	c1	mm	1100			1200			1300			1300			1450		
	d1	mm	570			570			570			570			570		
	a	mm	840			840			990			990			990		
	b	mm	380			380			480			480			480		
	L1	mm	420			430			460			520			450		
	L2	mm	670	1100	1500	680	1110	1510	800	1210	1710	850	1260	1760	950	1360	1860
LR	mm	250			257			277			288			189			
Motori cilindrici/Cylindrical motor	LM	mm	1175	1605	1995	1165	1595	1985	1305	1720	2220	1370	1790	2290	/	/	/
Motori conici/Conical motor	LM	mm	1065	1495	1885	1065	1495	1885	1125	1540	2040	1190	1610	2110	1290	1710	2210
Peso/Weight	≈	kg	1750	1900	2030	2030	2230	2410	2470	2720	3000	3170	3420	3700	3690	3940	4220

Velocità carrello / Trolley speed: 16 - 16/5,3 m/min



Paranchi speciali 8/1 8/1 special hoists

PARANCHI SPECIALI A SINGOLA USCITA FUNE DAL TAMBURO 8/1

SPECIAL HOIST WITH SINGLE OUTLET
FROM THE DRUM 8/1

SR8 A 8 TIRI DI FUNE (8/1) - 8 ROPE FALLS (8/1)

Fig. 5 PARANCO APPOGGIATO - SUPPORTED HOIST

**Fig. 53 CARRELLO PARANCO MONOROTAIA
HOIST TROLLEY BIRAIL**

SR8

Fig. 5

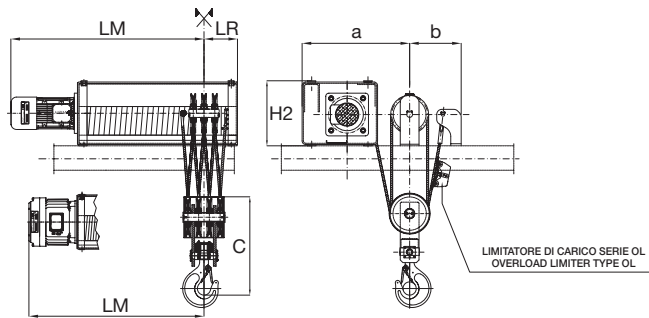

SR8

Fig. 53

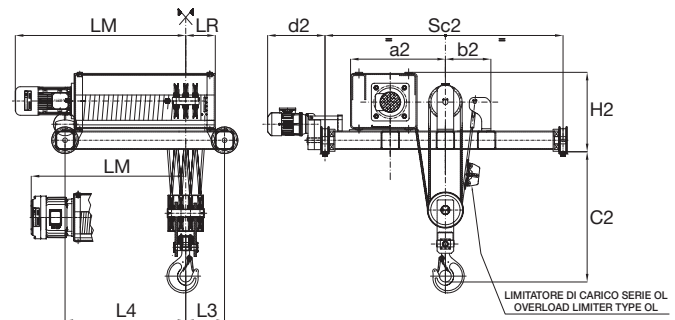

SR8 - A 8 TIRI DI FUNE (8/1) - SR8 - 8 ROPE FALLS (8/1)

Paranco/Hoist		XM	740			750			950			963			980		
Portata/Capacity		kg	32000			40000			40000			50000			64000		
Gruppo/Groupe		FEM	1Am			1Am			2m			1Am			1Am		
Corsa gancio/Hook travel		m	4,5	8	11	4,5	8	11	5	8	12	5	8	12	5	8	12
Motori cilindrici Cylindrical motor	Vel. soll./Lift. speed	m/min	2			2			3			2,5			2		
	Pot. mot./Mot. power	kW	12			15			24			24			24		
	Vel. soll./Lift. speed	m/min	2/0,7			2/0,7			2/0,7			2/0,7			-		
	Pot. mot./Mot. power	kW	12/4			15/5			16/5,3			22/7,3			-		
Motori conici Conical motor	Vel. soll./Lift. speed	m/min	2			2			1,5			1,2			1,2		
	Pot. mot./Mot. power	kW	12,5			15			12,5			12,5			16		
	Vel. soll./Lift. speed	m/min	2/0,5			2/0,3			1,5/0,4			1,2/0,3			1,2/0,3		
	Pot. mot./Mot. power	kW	13/3			15/2,5			13/3			13/3			16/4		
Fig 5	H	mm	530			530			625			625			625		
	c	mm	950			1080			1160			1160			1200		
	a	mm	840			840			990			990			990		
	b	mm	380			380			480			480			480		
	LR	mm	250			257			277			288			295		
Motori cilindrici/Cylindrical motor	LM	mm	1175	1605	1995	1165	1595	1985	1305	1720	2220	1370	1790	2290	/	/	/
Motori conici/Conical motor	LM	mm	1065	1495	1885	1065	1495	1885	1125	1540	2040	1190	1610	2110	1185	1605	2105
Peso/Weight	≈	kg	990	1090	1170	1110	1210	1190	1600	1750	1930	1600	1750	1930	1740	1890	2070
Fig 53	SC2	mm	2000			2000			2500			2500			2500		
	H2	mm	790			790			900			940			960		
	c1	mm	1150			1250			1350			1350			1500		
	d2	mm	570			570			570			570			570		
	a2	mm	840			840			990			990			990		
	b2	mm	380			380			480			480			480		
	L3	mm	430			490			520			520			600		
L4	mm	680	1110	1510	730	1160	1560	860	1270	1770	850	1260	1760	900	1310	1810	
LR	mm	250			257			277			288			295			
Motori cilindrici/Cylindrical motor	LM	mm	1175	1605	1995	1165	1595	1985	1305	1720	2220	1370	1790	2290	/	/	/
Motori conici/Conical motor	LM	mm	1065	1495	1885	1065	1495	1885	1125	1540	2040	1190	1610	2110	1185	1605	2105
Peso/Weight	≈	kg	2030	2230	2410	2840	3040	3220	3290	3540	3820	3290	3540	3820	3760	4010	4290

Velocità carrello / Trolley speed: 16 - 16/5,3 m/min

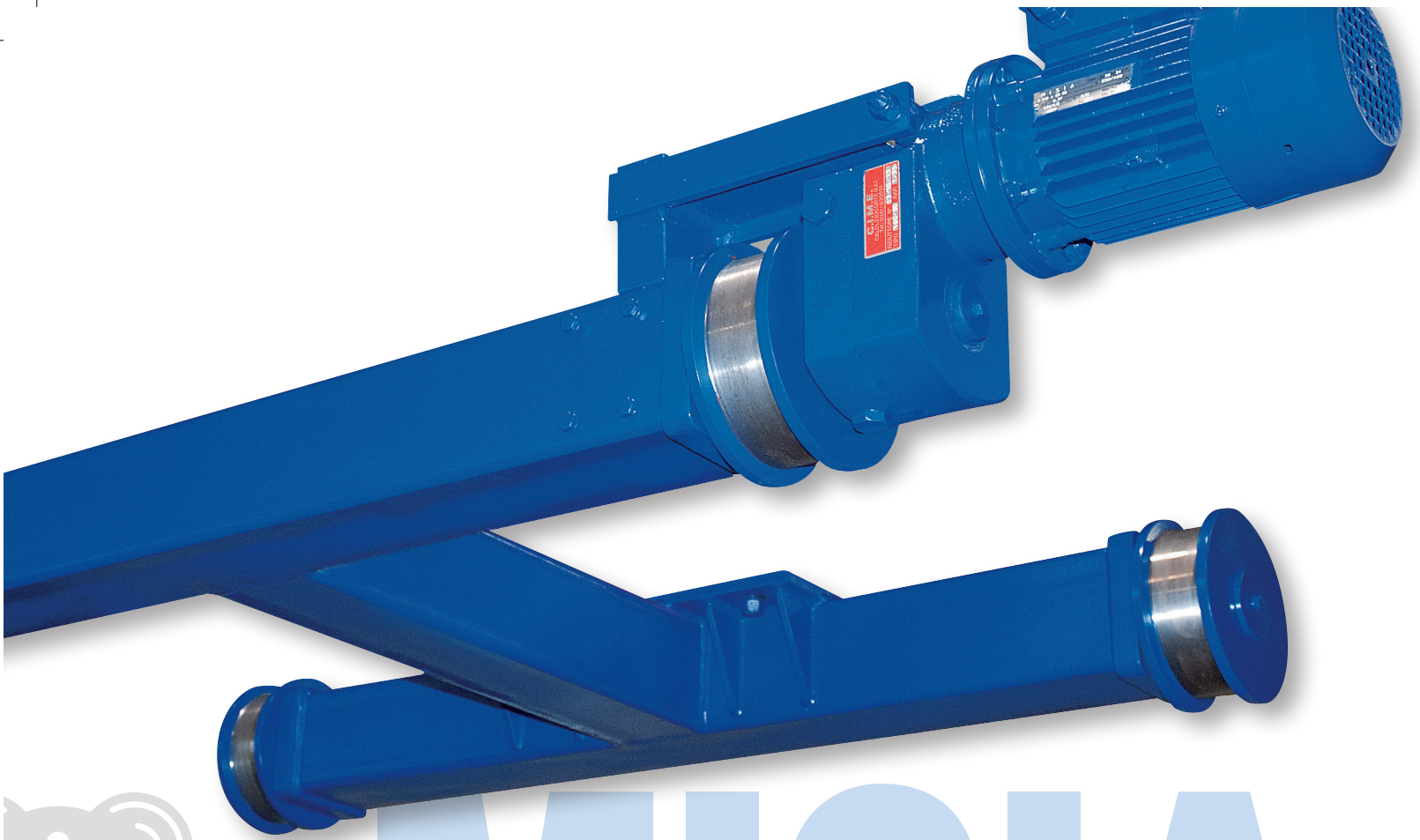

MISIA

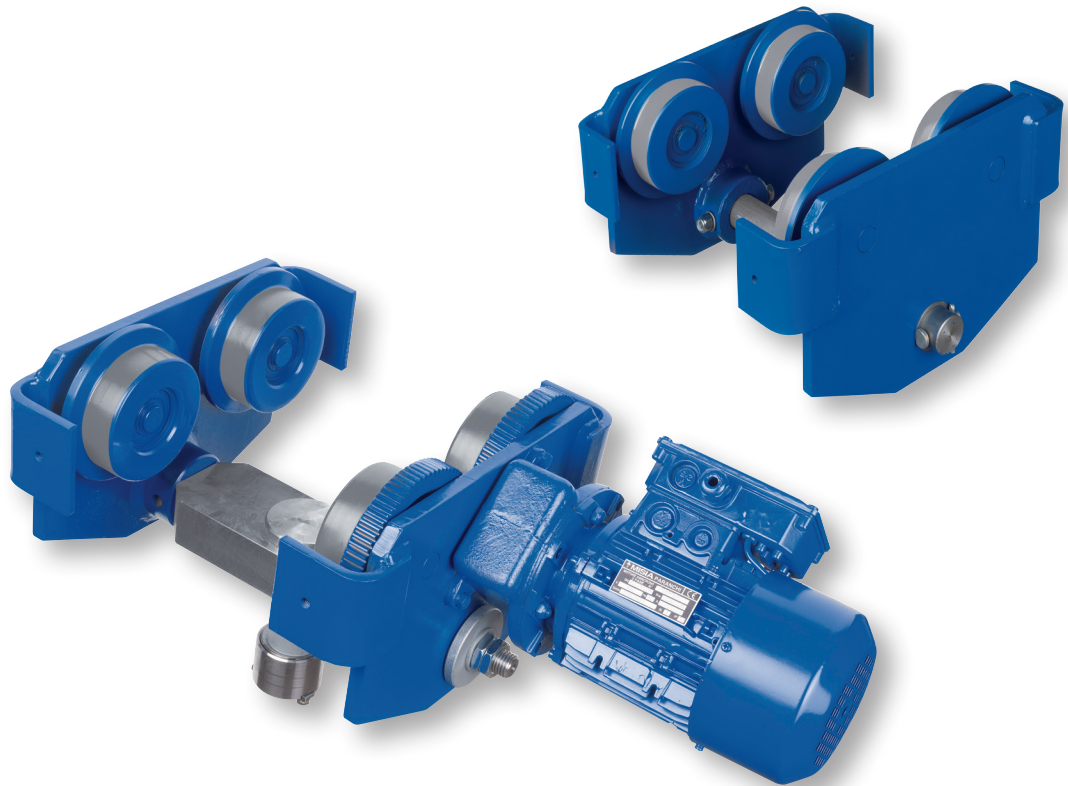
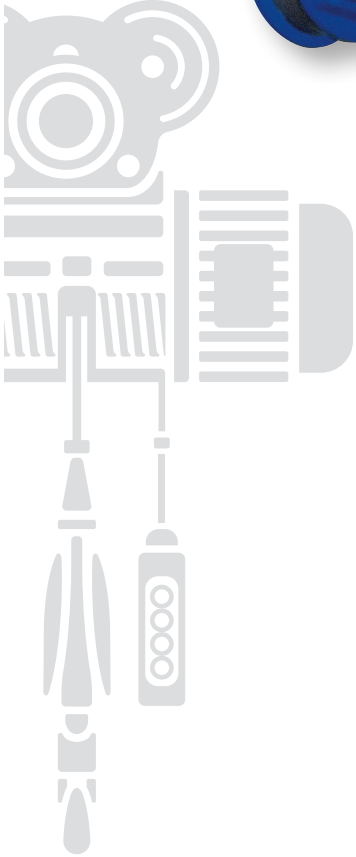

Carrelli
Trolleys



Carrelli monorotaia Monorail trolleys

CARRELLI PER MONOROTAIE RETTILINEE TROLLEYS FOR STRAIGHT MONORAIL

-A- CARRELLO MOTORE - DRIVING TROLLEY

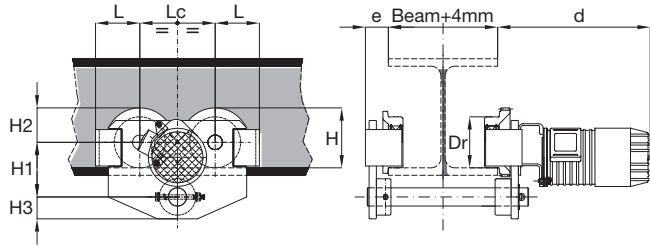

-B- CARRELLO FOLLE - IDLE TROLLEY

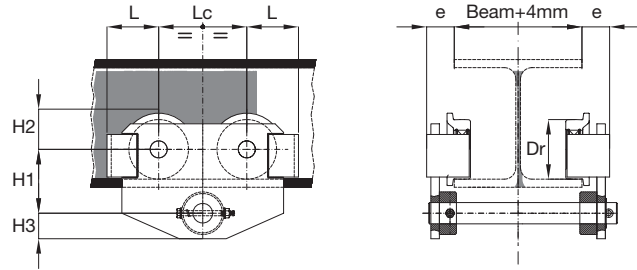

Portata max Max capacity kg	Dimensioni Dimensions									Velocità Speed m/min	Potenza Power kW	Peso Weight	
	DR mm	d mm	e mm	Lc mm	L mm	H mm	H1 mm	H2 mm	H3 mm			A kg	B kg
4500	120	450	60	183	110	142	130	60	50	18/6	0,37/0,12	65	45
10000	140	450	70	207	125	165	150	60	60	18/6	0,55/0,18	95	70
13250	140	450	100	207	125	165	150	60	60	18/6	0,55/0,18	98	73
25000	210	250	140	310	145	232	245	120	100	16/5,3	1,5/0,55	300	240

Carrelli monorotaia Monorail trolleys

CARRELLI PER MONOROTAIE CURVE TROLLEYS FOR CURVED MONORAIL

Per carrelli paranco a ingombro normale idonei a scorrere su monorotaie con curve e precisamente:
Portata fino a 4 t raggio min. 1500 mm.
Portata fino a 10 t raggio min. 2500 mm.

Articulated standard headroom monorail hoist units:
Lifting capacity up to 4 t (minimum radius 1500 mm).
Lifting capacity up to 10 t (minimum radius 2500 mm).

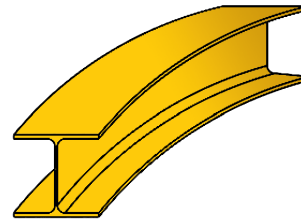

-A- CARRELLO MOTORE - DRIVING TROLLEY

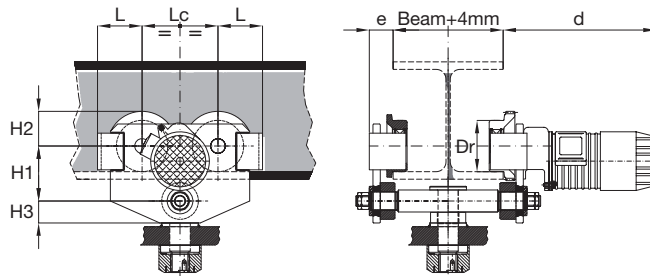

-B- CARRELLO FOLLE - IDLE TROLLEY

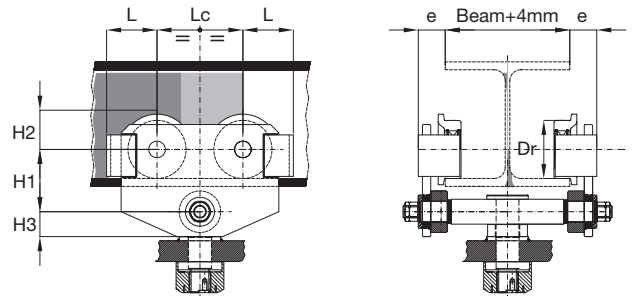

Portata max Max capacity kg	Raggio min Min radius m	Dimensioni Dimensions									Velocità Speed m/min	Potenza Power kW	Peso Weight	
		DR mm	d mm	e mm	Lc mm	L mm	H mm	H1 mm	H2 mm	H3 mm			A kg	B kg
4500	1,5	120	450	110	183	110	142	130	60	50	18/6	0,37/0,12	80	60
10000	2,0	140	450	120	207	125	142	150	60	60	18/6	0,55/0,18	120	95
13250	2,0	140	450	140	207	125	165	150	60	60	18/6	0,55/0,18	130	105
25000	3,5	210	250	140	310	145	232	245	120	100	16/5,3	1,5/0,55	360	300



Carrelli birotaia Birail trolleys

CARRELLI BIROTAIA PER GRU A PONTE BIRAIL TROLLEYS FOR BRIDGE CRANE

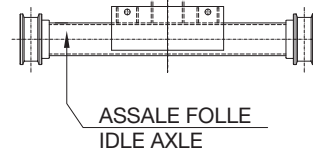
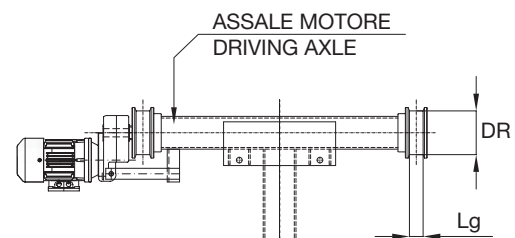
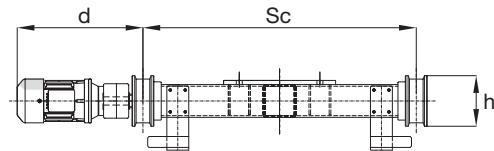
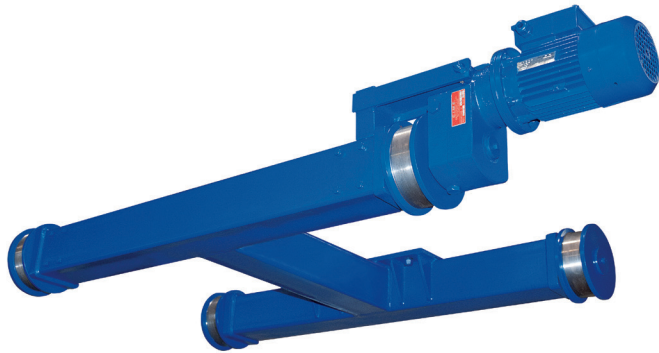

Portata max Max capacity	Dimensioni Dimensions					Velocità Speed		Potenza Power	Peso Weight
	kg	Sc mm	d mm	DR mm	Lg mm	h mm	m/min		
6300	1000	480	160	50	175	16/5,3	20/6,5	0,37/0,12	200
10000	1000	510	160	50	175	16/5,3	20/6,5	0,55/0,18	230
16000	1200	540	200	60	220	16/5,3	20/6,5	0,75/0,25	460
25000	1450	570	250	60	270	16/5,3	20/6,5	1,5/0,55	790
32000	1450	570	320	70	345	16/5,3	20/6,5	2x1,1/0,37	990
40000	2000	590	320	90	345	16/5,3	20/6,5	2x1,5/0,55	1700
50000	2000	590	320	90	345	16/5,3	20/6,5	2x1,5/0,55	1750

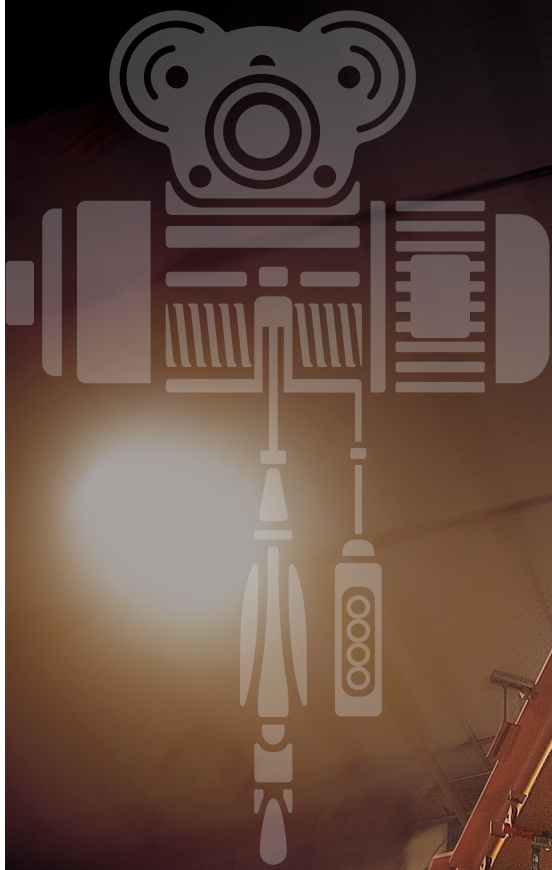

MISIA



Accessori
Accessories



Bozzelli Hook blocks

BOZZELLI A 2 TIRI DI FUNE "S2" A 4 TIRI DI FUNE "S4"

"S2" 2 ROPE FALLS

"S4" 4 ROPE FALLS HOOK BLOCKS



S2 (2/1) GANCI NORMA DIN 15401 - HOOKS NORME DIN 15401

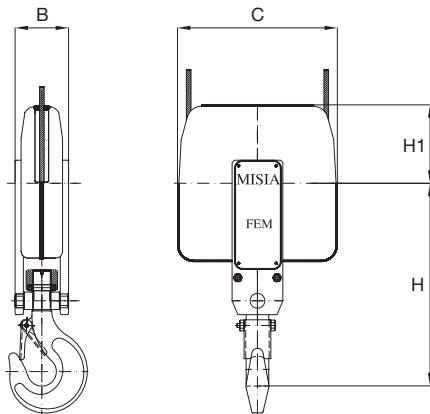

Portata max Max capacity	Gruppo Groupe	Ø Fune Rope Ø	Ø Puleggia Roller Ø	Dimensioni Dimensions				Numero gancio Hook number	Peso Weight
				H mm	H1 mm	B mm	C mm		
1,6	2 m	7	195	330	122	95	244	1	15
3,2	2 m	10	233	375	144	105	288	1,6	25
5	2 m	12	276	440	170	125	340	2,5	35
8	2 m	15	352	525	218	145	436	4	60
10	1 Am	15	352	665	218	145	436	6	90
12,5	1 Am	20	430	665	265	165	530	6	90
16	1 Am	20	430	665	265	165	530	6	90
25	1 Am	30	565	900	340	190	680	10	140

S4 (4/1) GANCI NORMA DIN 15401 - HOOKS NORME DIN 15401

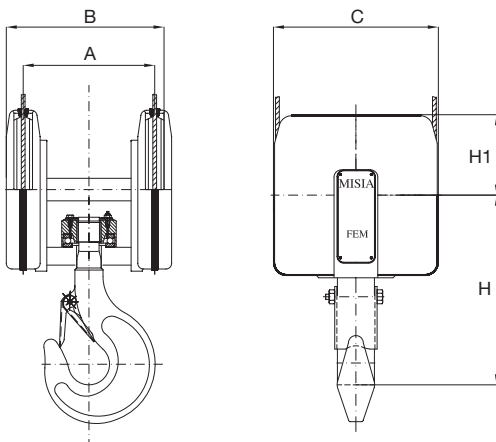

Portata max Max capacity	Gruppo Groupe	Ø Fune Rope Ø	Ø Puleggia Roller Ø	Dimensioni Dimensions					Numero gancio Hook number	Peso Weight
				H mm	H1 mm	A mm	B mm	C mm		
3,2	2 m	7	195	280	122	155	225	244	1,6	30
5	2 m	10	233	325	144	250	325	288	2,5	40
6,3	2 m	10	233	345	170	250	325	288	4	45
10	2 m	12	276	440	218	300	390	340	6	80
16	1 Am	15	352	510	218	350	460	436	6	110
20	1 Am	15	352	510	218	350	460	436	10	130
20	2 m	20	430	560	265	440	575	530	10	135
25	1 Am	20	430	560	265	440	575	530	10	135
32	1 Am	20	430	650	265	440	575	530	16	160
50	1 Am	30	565	700	340	510	645	680	16	280



Limitatori di carico Serie OL Overload limiter OL Series

**APPLICAZIONE DIRETTA SULLE FUNI
DEGLI APPARECCHI DI SOLLEVAMENTO**
DIRECT APPLICATION ON THE ROPE
OF THE LIFTING TOOLS.

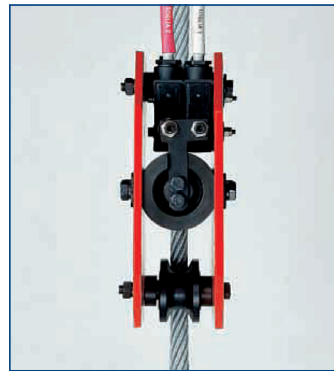
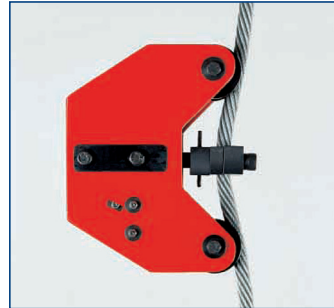

LIMITATORI DI CARICO - OVERLOAD LIMITER

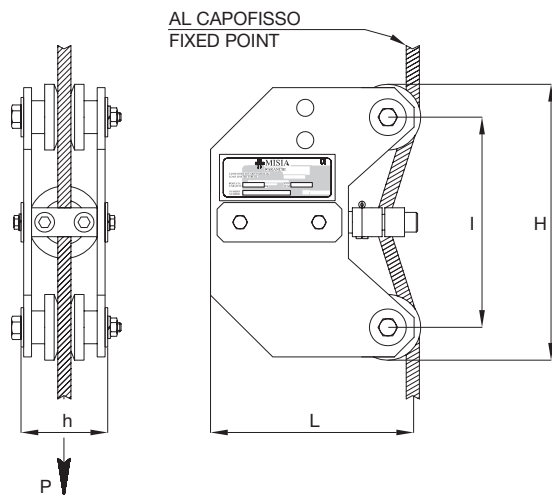

Tipo Type	P max kg	Ø Fune Rope Ø mm	Dimensioni Dimensions				Peso Weight Kg
			I mm	H mm	L mm	H mm	
OL 10	1000	7 ÷ 10	120	160	135	65	3,5
OL 25	2500	10 ÷ 14	160	210	160	80	5
OL 50	5000	14 ÷ 20	200	295	175	120	14



Riduttori a albero cavo Hollow shaft gear unit

RIDUTTORI A ALBERO CAVO PER CARRELLI E GRU A PONTE HOLLOW SHAFT GEAR UNIT FOR TROLLEYS AND BRIDGE CRANES

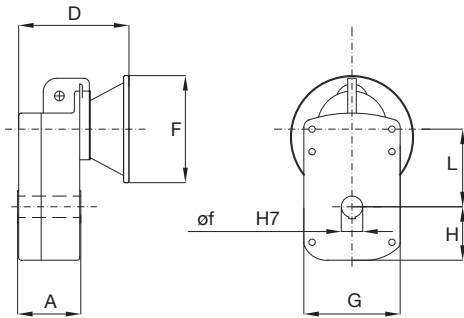

Tipo riduttore "TP" Reducer type "TP"	160	200	250	315	400	500
Ø f mm	30	35	40	50	60	70
L mm	100	125	145	174	230	270
H mm	63	72	88	102	127	145
G mm	130	150	180	210	265	300
A mm	99	110	122	150	193	208
Grandezza motore Motor size	71	71	80-90	100-112	100-112	100-112
F mm	160	160	200	250	250	250
D mm	149	162	196	219	312	327
Grandezza motore Motor size	80-90	80-90	100-112	132	132	132
F mm	200	200	250	300	300	300
D mm	169	182	206	229	312	327
Peso kg Weight kg	13	20	30	43	75	100

RAPPORTI DI RIDUZIONE DISPONIBILI - POTENZE MASSIME APPLICABILI CON MOTORI A 4 POLI AVAILABLE RATIOS - MAXIMUM POWER FOR 4 POLES MOTOR

TP 160	
P1 kW	i 1:x
0,25	79
0,25	70
0,25	64
0,37	58
0,37	56
0,37	49
0,37	48
0,37	47
0,37	45
0,37	43
0,55	39
0,55	36
0,55	35
0,55	33
0,55	30
0,75	29
0,75	28
0,75	27
0,75	22
1,1	20
1,1	16
1,5	13

TP 200	
P1 kW	i 1:x
0,37	84
0,55	70
0,55	69
0,75	57
0,75	54
0,75	50
0,75	44
0,75	43
0,75	41
1,1	40
1,1	35
1,1	33
1,1	32
1,5	27
1,5	25
1,5	22
2,2	20
2,2	18

TP 250	
P1 kW	i 1:x
0,75	88
0,75	79
0,75	72
0,75	66
0,75	65
1,1	61
1,1	60
1,1	54
1,1	52
1,1	50
1,1	48
1,5	46
1,5	39
1,5	36
2,2	27
3	20

TP 315	
P1 kW	i 1:x
0,75	108
1,1	93
1,1	86
1,1	78
1,5	70
1,5	65
1,5	60
1,5	59
1,5	58
1,5	54
1,5	51
2,2	46
2,2	45
2,2	41
3	35
3	29
3	27
4	20

TP 400	
P1 kW	i 1:x
1,5	114
1,5	105
1,5	95
1,5	87
2,2	80
2,2	73
2,2	68
2,2	63
3	59
3	54
3	48
4	44
4	36
5,5	32

TP 500	
P1 kW	i 1:x
1,5	129
2,2	117
2,2	98
3	89
3	83
3	77
3	75
3	71
3	70
4	66
4	65
4	64
4	62
4	60
4	56
5,5	48
5,5	41
5,5	38
7,5	35
7,5	33
7,5	31



Testate per gru a ponte Girders end-carriages

TESTATE PER GRU A PONTE BITRAVE - DOUBLE GIRDERS END-CARRIAGES

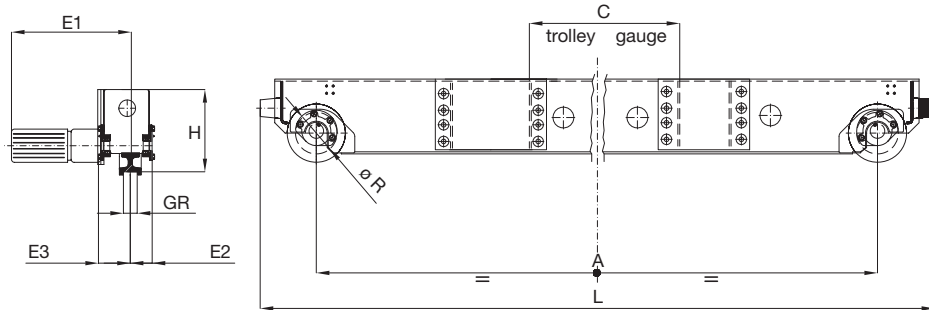

	Tipo / Type "DG"																		
	30	33	34	36	37	38	86	40	41	42	49	87	88	89	90	91	92	96	
	Carico max sulla ruota kN - Max wheel load kN																		
Ø R	38	54	50	71	78	88	68	114	128	148	159	102	220	149	212	250	315	250	
GR	160	200		250				315					400			500			400
H	70			375				385	403	483	403	90						533	
E1	267	335		620				760					740				533		
E2	550	610		115				130					165			161	130		
E3	94	105		165				180					165			161	180		
SC	1000						1200			1450			1000	1450	1200	1450	2000		
A	2000	2500	3150	2500	3150	3700	4600	3150	3700	2700	4600	3700	4600			3700			
L	2480	3000	3650	3045	3695	4245	5145	3880	4430	3430	5330	4540	5440		5880		4460		
Peso kg Weight kg	410	560	680	760	890	1090	1300	1130	1500	1500	1060	1740	2250	2550	2930	3490	3510	2280	

TESTATE PER GRU A PONTE MONOTRAVE - SINGLE GIRDERS END-CARRIAGES

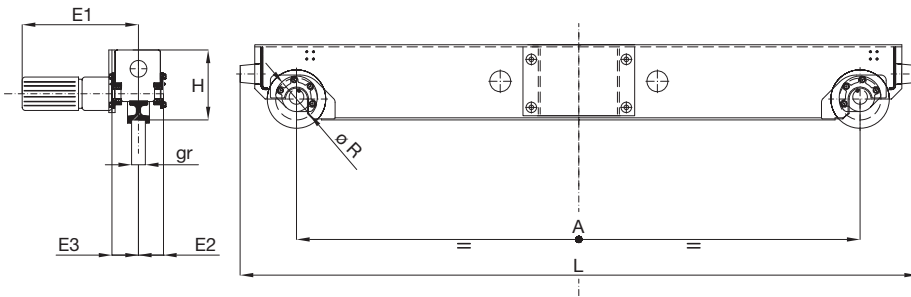

	Tipo / Type "SG"															
	62	57*	63	58	64	65	45	46	44	66	69	48	60	67	68	
	Carico max sulla ruota kN - Max wheel load kN															
Ø R	24	29	27	32	30	35	36	39	43	45	68	54	88	75	100	
GR	125		160				200				250					315
H	60		70					80			80					
H	248		267				335				375	400			405	
E1	550		560				620				650				760	
E2	90		95				105				115				130	
E3	90		95				155				165				180	
A	1500		2200			2700	3700	2350	2700	3700	4700	2350	2700	3700	4700	
L	1940	1880	2640	2680	3180	4200	2850	3200	4200	5200	2900	3250	4250	5300	5400	
Peso kg Weight kg	290	270	420	420	530	780	530	620	795	1070	780	860	1170	1500	2150	

* Testate per gru monotrave in profilato HE / End-carriages for HE beam bridges

Componenti elettrici
Electrical components

Quadro elettrico con morsetti e pressacavi per paranco; carrelli paranchi e gru
Electrical panel plug and play “male/female” system



Pulsantiera pensile completa di cavo e connettore
Pendant push button complete of cable and plug socket



Radiocomando completo di cavo e connettore
Wireless remote control complete of cable and plug socket



Quadro elettrico con connettori per paranco; carrello paranco e gru
Electrical control panel with connectors; hoist trolley and crane



Inverter
Vfd control



Linee di alimentazione a festoni in canalina per percorsi rettilinei

Festoon feeding line channel for straight way

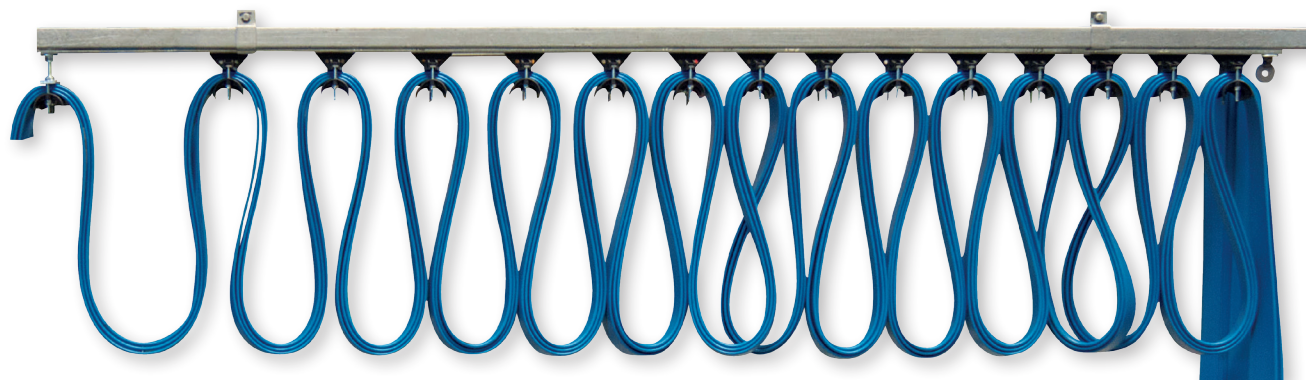

Linea di alimentazione a festoni in canalina quadra per percorsi curvi

Festoon feeding line in square channel for curved way



Linea di contatto isolata per percorsi dritti o con curva

Multi pole conductor rail for straight or curved way

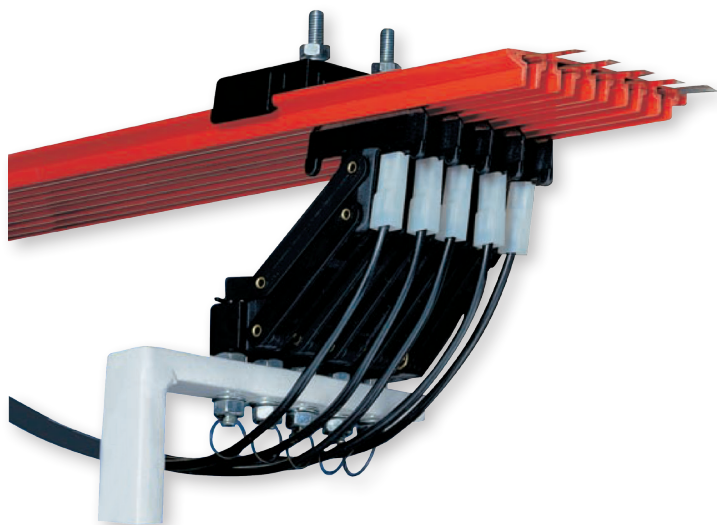

Blindo trolley

Bus bar

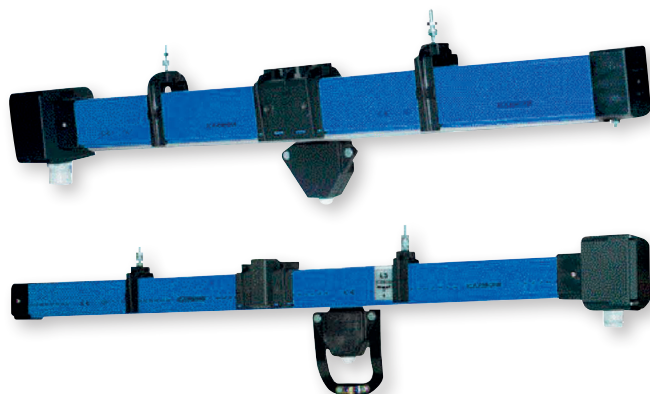

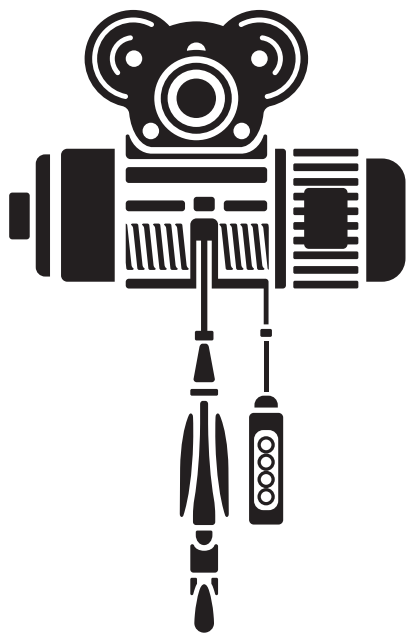

MISIA

Paranchi elettrici a fune
Wire rope hoists

www.misia.com

